

clawFRplus[®]

10 DEGREE

Installation Manual

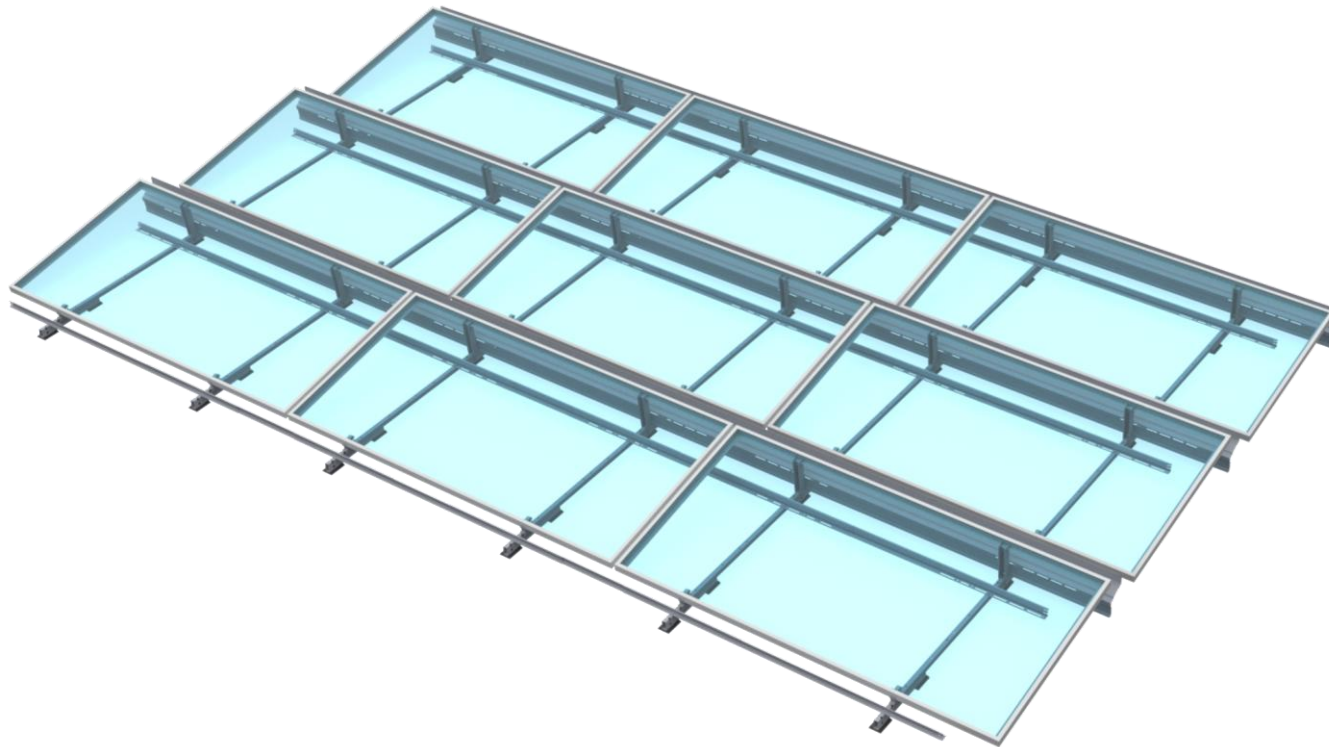

Table of Contents

Disclaimers	2
Ratings & Markings	3
System Components	4
Accessories	4
Tools, Torque, & Construction Aid	5
Construction Aid Setup	6
Build Assemblies	7
Build North Row	8
Rail Installation	9
Build Remaining Rows	10
2000695/2000895 Rail Installation	11
2000905 Ballast Rail Installation	12
Install Module Low Side	13
Install Module High Side	14
Continue Installing Modules	15
Install Deflectors	16
Electrical Grounding	17
Appendix	18

Disclaimers

Introduction

The clawFRplus 10 Degree flat roof mounting system is comprised of four major components that intuitively assemble into a support structure for photovoltaic (PV) modules. This installation manual explains how to build a PV array using clawFRplus 10 Degree.



EXCEPT FOR DEFLECTORS, ALL RACKING COMPONENTS IN EACH SUBARRAY AND THEIR CONNECTIONS, BALLAST, AND MECHANICAL ATTACHMENTS (IF ANY IN DESIGN) MUST BE INSTALLED BEFORE MOUNTING MODULES. WHEN FORECASTED WIND GUSTS EXCEED 25% OF THE WIND SPEED LISTED IN THE SITE CRITERIA TABLE OF THE RACKING CONSTRUCTION SET, DEFLECTORS MUST BE INSTALLED ON ALL MOUNTED MODULES TO AVOID POSSIBLE SYSTEM DAMAGE.



A CORROSION INSPECTION ONE YEAR AFTER INSTALLATION AND ONCE EVERY THREE YEARS THEREAFTER IS REQUIRED TO MAINTAIN THE PRODUCT WARRANTY. VISIBLE SURFACE RED RUST ON STEEL COMPONENTS MUST BE LOCALLY COATED WITH A COMMERCIALY AVAILABLE GALVANIZED PAINT OR COATING TO MAINTAIN PRODUCT WARRANTY.



THIS PRODUCT MUST BE INSTALLED AND USED ACCORDING TO THESE WRITTEN INSTRUCTIONS. ANY INSTALLATION OR USE OF THIS PRODUCT NOT IN ACCORDANCE WITH OR NOT AUTHORIZED BY THIS MANUAL SHALL VOID ANY AND ALL WARRANTIES, EXPRESS OR IMPLIED, ON THE PRODUCT OR THE USE OF THE PRODUCT AND MAY CAUSE FAILURE, PROPERTY DAMAGE AND PERSONAL INJURY. PANELCLAW IS NOT LIABLE FOR ANY UNAUTHORIZED USE. INSTALL AND USE ONLY WITH OTHER PANELCLAW **AUTHORIZED** RACKING PRODUCTS TO ENSURE PROPER FIT AND FUNCTION.



PRIOR TO INSTALLATION, READ THE SAFETY PROVISIONS ATTACHED IN [Appendix F: Safety](#) AND REVIEW THIS INSTALLATION MANUAL IN ITS ENTIRETY.

Sub Array Dimensions

Each PV system is unique and is frequently made up of multiple sub arrays. The Racking Construction Set, which must be onsite at all times during construction, details sub array dimensions and location on the roof. Review the Racking Construction Set in its entirety to prevent unnecessary rework during site construction.

The furthest extent of the racking components or modules of adjacent sub arrays, whichever defines the outermost array boundaries, must be separated by *at least* the minimum dimensions documented in the Racking Construction Set. Refer to the **general notes** and the **Minimum Clearance Requirements table**, if present, within the Racking Construction Set.

Storage Considerations

PanelClaw recommends installing the racking components shortly after delivery to the project site. If clawFRplus components are not deployed immediately, they should be stored in a well-ventilated, dry location. Otherwise, moisture can form between the packed components which may cause staining and/or white rust. Significant white rust formation may decrease the coating service life and, in extreme cases, the component performance.

If storage onsite is unavoidable, remove the plastic and/or cardboard wrapping from the exterior of the packaging and cover with canvas or place components under an open sided tent. Note the use of a plastic cover does more harm than good as it prevents the product from breathing and causes condensation. Storing parts in any other manner is at the customer's **own** risk. PanelClaw is not liable for claims related to improper storage and any such claims are not covered by the product warranty.

Operations & Maintenance

See O&M Manual, available upon request, for initial inspection recommendations including steps that can be performed only during construction.

Installer's Responsibility

IT IS THE INSTALLERS RESPONSIBILITY TO:

- Ensure safe installation of all electrical aspects of the array. All electrical installation and procedures should be conducted by a licensed and bonded electrician or solar contractor. Routine maintenance of a module or panel shall not involve breaking or disturbing the bonding path of the system. All work must comply with national, state and local installation procedures, product and safety standards.
- Comply with all applicable local or national building and fire codes, including any that may supersede this manual.
- Ensure all products are appropriate for the installation, environment, and array under the site's loading conditions.
- Use only PanelClaw parts or parts recommended by PanelClaw; substituting parts may void any applicable warranty.
- Ensure provided information is accurate. Issues resulting from inaccurate information are the installer's responsibility.
- Ensure bare copper grounding wire does not contact aluminum and zinc-plated steel components, to prevent risk of galvanic corrosion.
- If loose components or loose fasteners are found during periodic inspection, retighten immediately. Any components showing signs of corrosion or damage that compromise safety shall be replaced immediately.
- Provide an appropriate method of direct-to-earth grounding according to the latest edition of the National Electrical Code, including NEC 250: Grounding and Bonding, and NEC 690: Solar Photovoltaic Systems.
- Disconnect AC power before servicing or removing modules, AC modules, microinverters, and power optimizers.
- Review module and any 3rd party manufacturer's documentation for compatibility and compliance with warranty terms and conditions.

Safety Overview

Safety is an essential part of every PV installation and every construction site. Please view [Appendix F: Safety](#) for further information.

Ratings

UL 2703 Listing:

clawFRplus Conforms to UL STD 2703 Standard for Mounting Systems, Mounting Devices, Clamping/ Retention Devices, and Ground Lugs for Use with Flat-Plate Photovoltaic Modules and Panels and Certified to CSA TIL No. A-40.

- Max Overcurrent Protective Device (OCPD) Rating: 40A
- Max Module Size: 36.8 ft²
- Module Orientation: Landscape
- System Design Load Rating: 30psf downward, 30psf upward, 5psf lateral
- Actual system structural capacity defined by the PE stamped calculation package and racking construction set

Fire Rating:

The clawFRplus system has a CLASS A SYSTEM FIRE RATING PER UL 2703

- Low Slope Roofs (less than 2:12) with Module Types 1, 2, 3, 13, 16, 19, 22, 25, 29, 30 and 38
- Class A Fire rating is applicable with or without wind deflectors. Review PanelClaw Racking Construction Set for deflector configuration requirements.
- Class A rated PV systems can be installed on Class A, B, and C roofs without affecting the roof fire rating.

UL 3741 Listing:

clawFRplus Conforms to ANSI/CAN/UL STD 3741 Standard for Safety Photovoltaic Hazard Control System

- Refer to clawFR/clawFRplus UL 3741 PV Hazard Control Installation Addendum for full ratings, approved equipment, components, and installation requirements.

Markings

Markings are located on the clawFRplus Tilt Arm, as shown below:

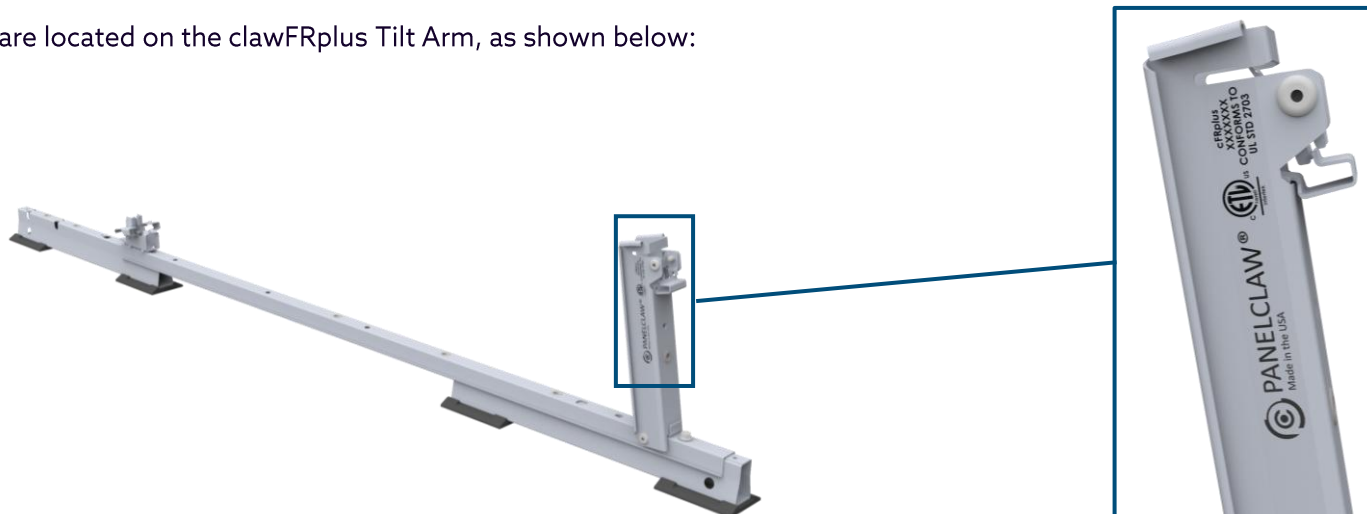

System Components

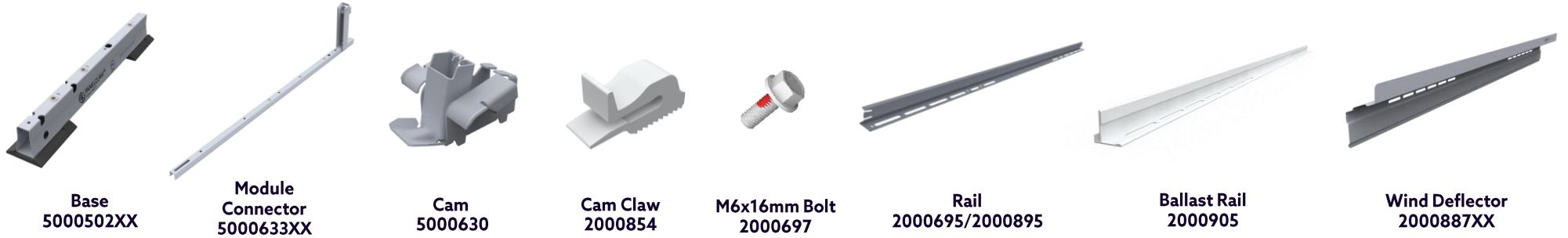

Accessories

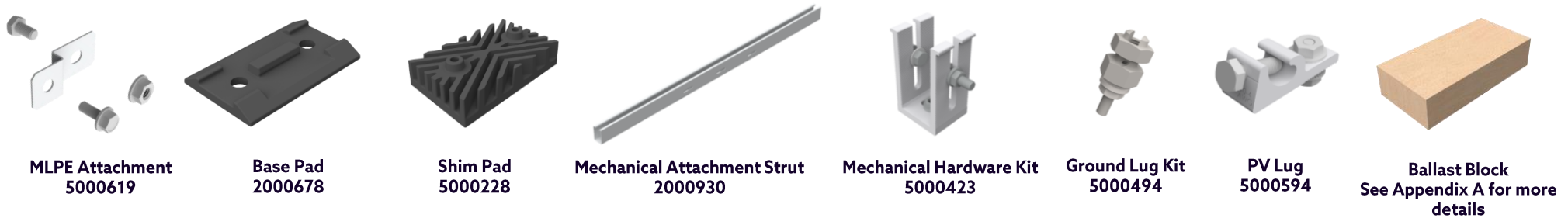

Wire Management

See: 9910053-Wire Management Manual

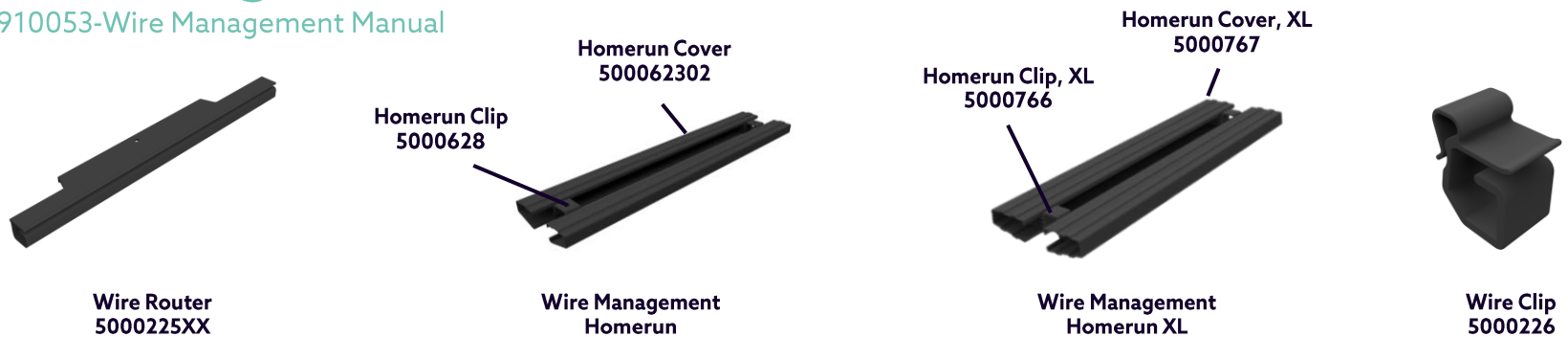



Spacer Stick and Cam Spacer Kit
5000510/5000610
2000761 may be required, see page 6
for more information

Tools

Drill with Inline-Torque Limiter or Torque Wrench

10 mm Magnetic Nut Driver

ALERT: NO IMPACT DRIVERS

Torque Setting*	Fastening Operation
6 ft-lb (8.1 Nm)	All System connections except Special Cases
3 ft-lb (4.1 Nm)	Special Cases

* +/-4% allowable during installation

Note: Additional tools may be required when installing accessories.

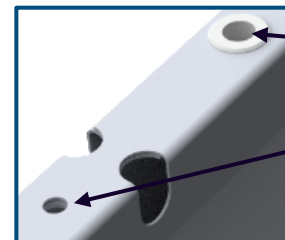

Bolts which are installed into a pre-installed nut are tightened to **6 ft-lb**

Bolts which are installed into a pilot hole are tightened to **3 ft-lb**

ALERT: During installation into the Pilot hole and Torque Clip if applicable. The use of a battery-operated drill (Not impact driver) Should be set to low speed, no clutch (set to drill) and an even amount of force perpendicular to the connection should be applied.

1. Construction Aid Setup

Tip: L, S, and Cam Spacer dimensions are found in the Racking Construction Set. See Sheet Title: **Typical Array Dimensions.**

1.1 Assemble the Spacer Stick and adjust to L & S dimensions. All dimensions are measured from the Base centerlines.

Tip: To stiffen the Spacer Stick, place one Rail 2000695/2000895 on the assembly as shown, shift the Rail to find a location which allows for attachment with the specified bolts. Tighten the bolts.

1.2 Insert the bolt and adjust the Cam Spacer to the Cam Spacing dimension.

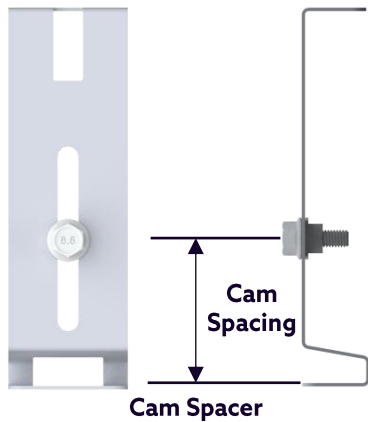
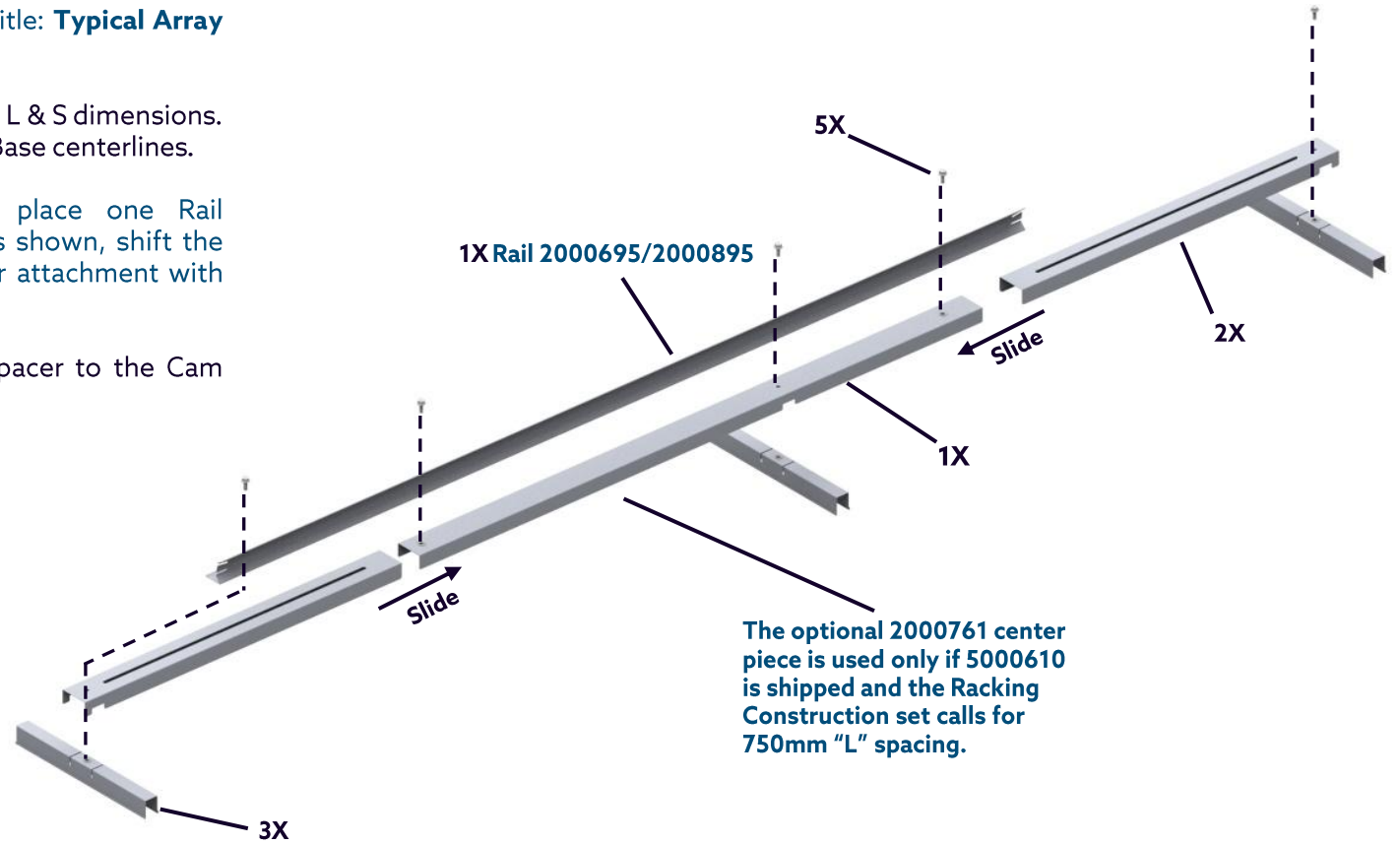

Typical Cam Spacer Usage

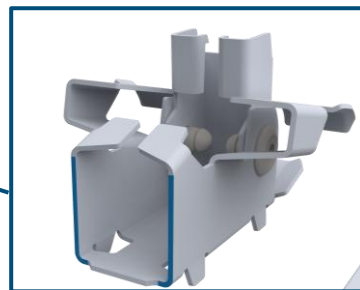
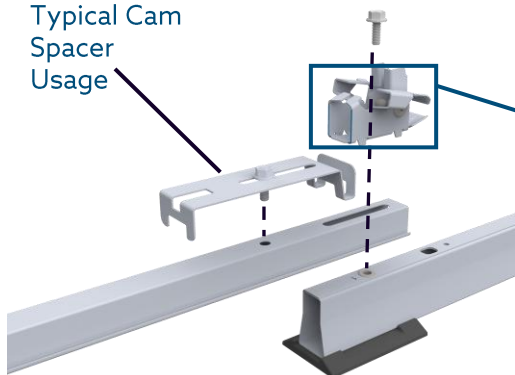

Tip: Cam Spacing is measured off the highlighted face and not the extended tab on the back of the Cam Bracket

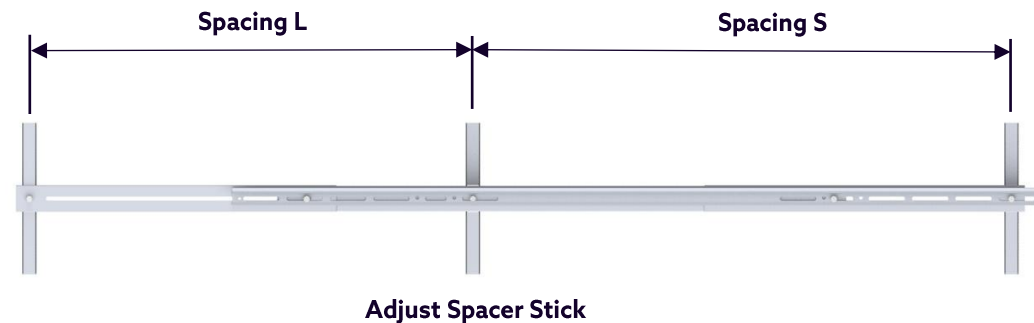

2. Build Assemblies

2.1 Position components as required per assembly type and loosely assemble the Cam, Module Connector and Base.

ALERT: Note location of orientation marker on Base "●"

Tip: Base length may vary depending on the row spacing option.

Tip: Immediately tighten bolts at the Tilt Arm end of the assembly to **6 ft-lb**.

2.2 Use the Cam Spacer tool to correctly locate the Module Connector. Tighten bolt to **6 ft-lb**.

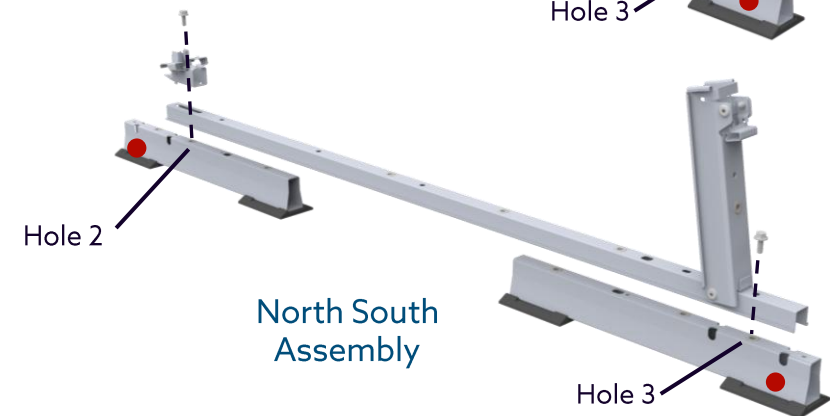
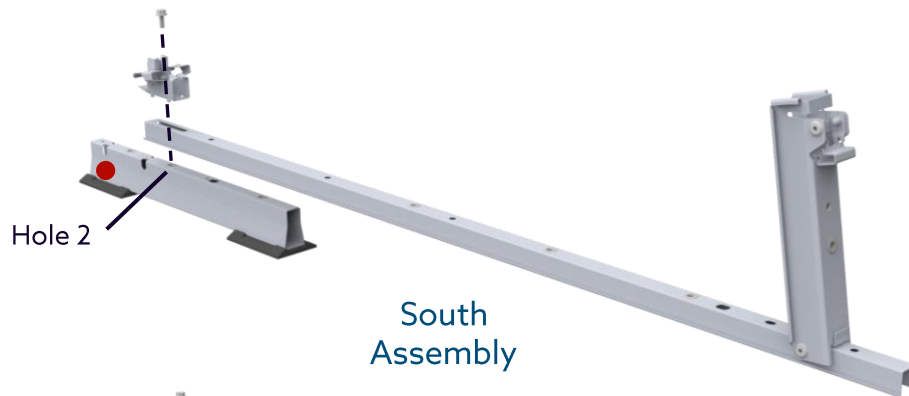
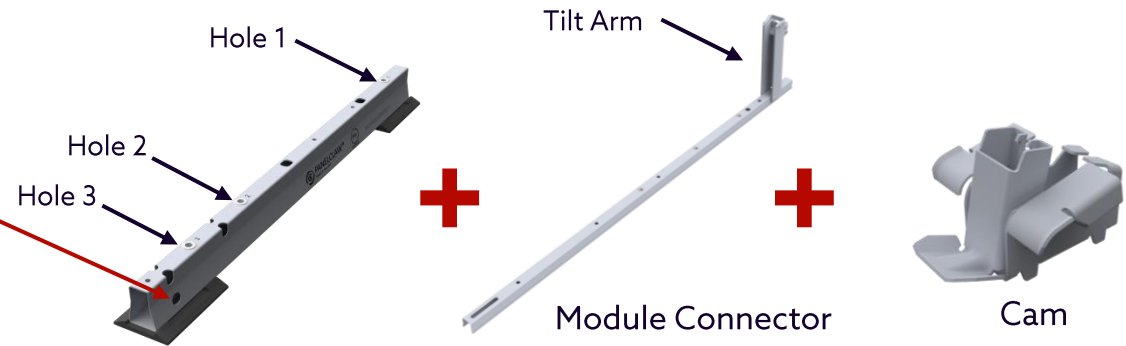

3. Build North Row

3.1 Snap North Edge, Array Edge, and Base Edge lines.

Tip: Snap Array Edge lines on one or both array edges (row ends) and snap Base Edge line on the edge where module mounting will begin.

3.2 Place North Assemblies with the Base Pads along the North Edge line. The first and last North Assemblies should be placed with the edge of the Base Pads on the Base Edge line.

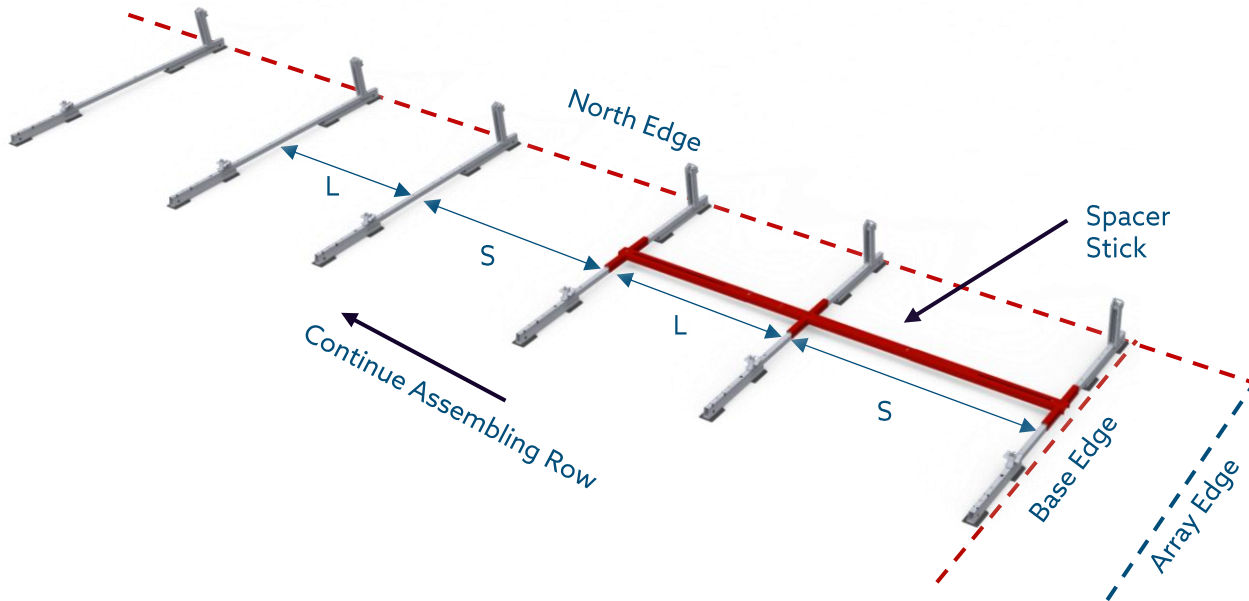
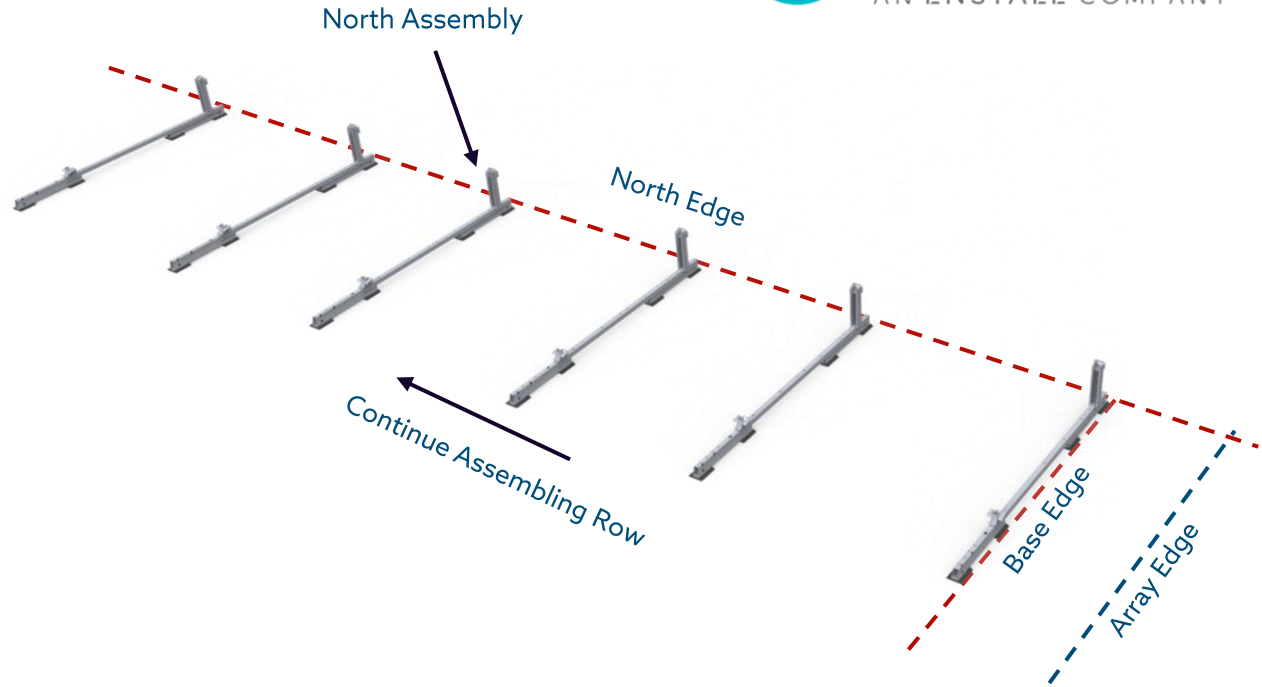

3.3 To align the Module Connectors before Rail installation, utilize the Spacer Stick to secure the Module Connectors.

Tip: "S" spacings are module centered "L" spacings are between modules.

Tip: L, S, R and AEBE dimensions are found in the Racking Construction Set. See Sheet Title: **Typical Array Dimensions.**

4. Rail Installation

4.1 Place a Rail on all "S" spacings (module centered). Rails at ends of rows should be flush with array edge when "S" spacings permits.

Place a Rail on all "L" spacings (between modules) on top of and overlapping the Rails on the "S" spacing. Install bolt and tighten to **6 ft-lb**.

ALERT: Tighten fasteners prior to moving spacer stick to next position.

4.2 Install Rails throughout the array using the same steps described in 4.1. Alternating between "S" and "L" Spacings. Install bolt and tighten to **6 ft-lb**.

ALERT: To ensure system alignment, use the spacer stick to align Module Connectors before securing Rails.

Tip: Rail has two holes. Consult Sheet Title: **Typical Array Dimensions** in the Racking Construction Set for appropriate hole use.

ALERT: "L" Rails must sit on top of "S" Rails. Otherwise, system rigidity is compromised.

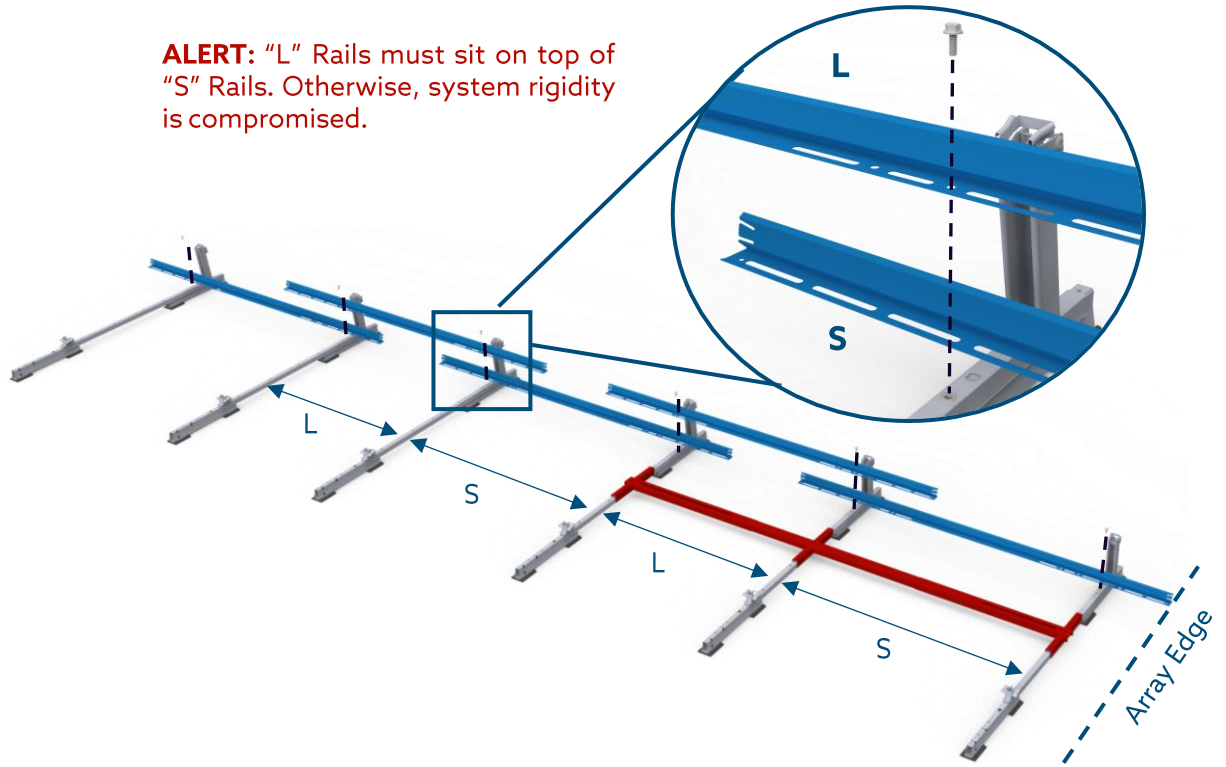

4.3 In cases where a contiguous array has module omissions, additional Rails must be installed as shown.

Bolts which are installed into a pre-installed nut are tightened to **6 ft-lb**.

Bolts which are installed into a pilot hole are tightened to **3 ft-lb**.

Rails installed across the edge to connect the row

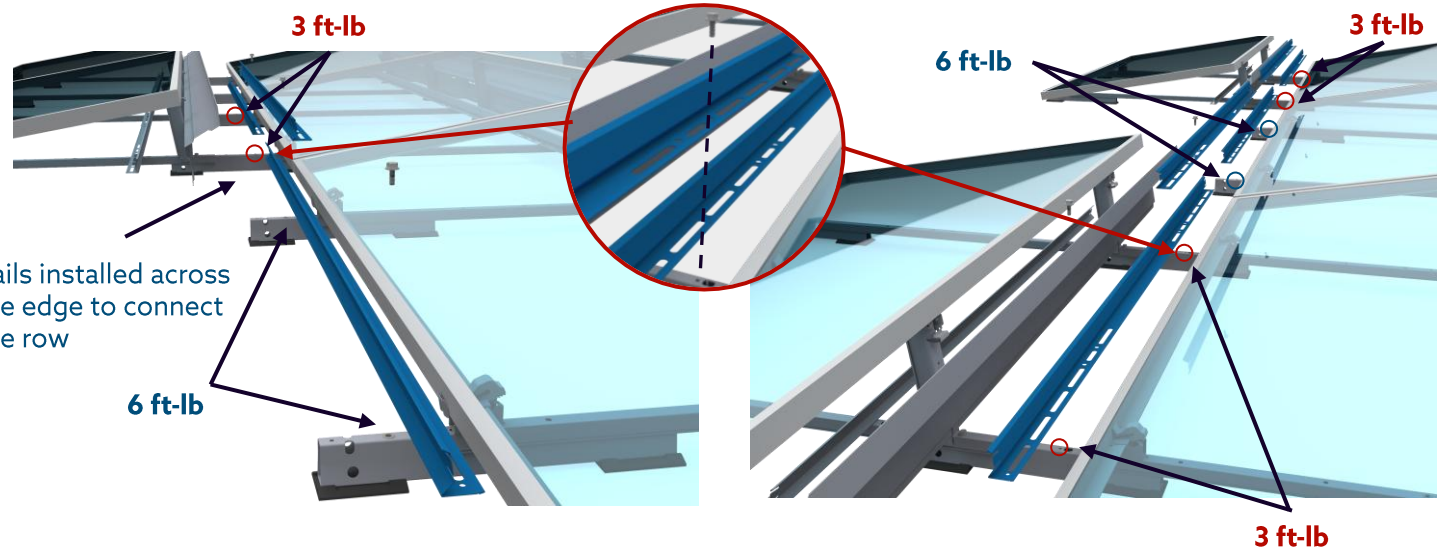

5. Build Remaining Rows

5.1 Place "Middle" or "South" Assemblies onto Assemblies from previous row and bolt to **6 ft-lb.**

Alert: Sheet Title: **Assemblies** in the Racking Construction Set clearly indicates hole selection. Using the wrong hole will result in an array which does not match site plan.

5.2 After placing "Middle" and "South" Assemblies, install Rails following the same procedure in Step 4, under all modules and for all Southern Edges. Southern Edge Rails are installed in the opposite orientation. Installing in the incorrect orientation may prevent module tilt up.

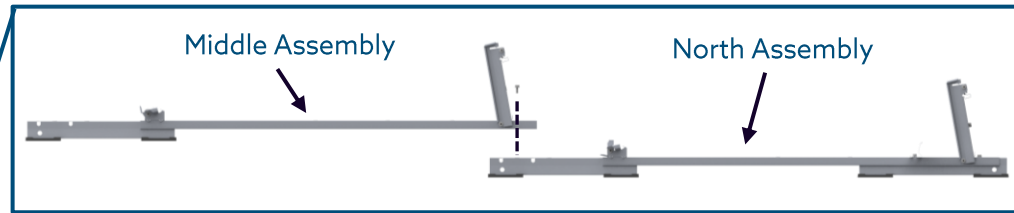

Tip: Raise Tilt Arms after bolting assemblies in preparation for Rail installation.

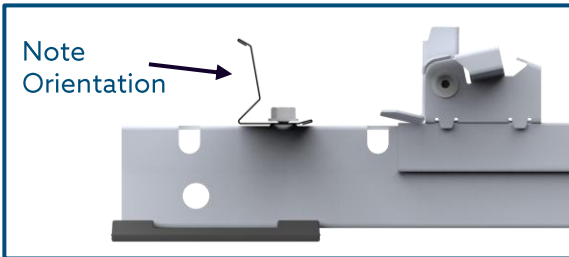
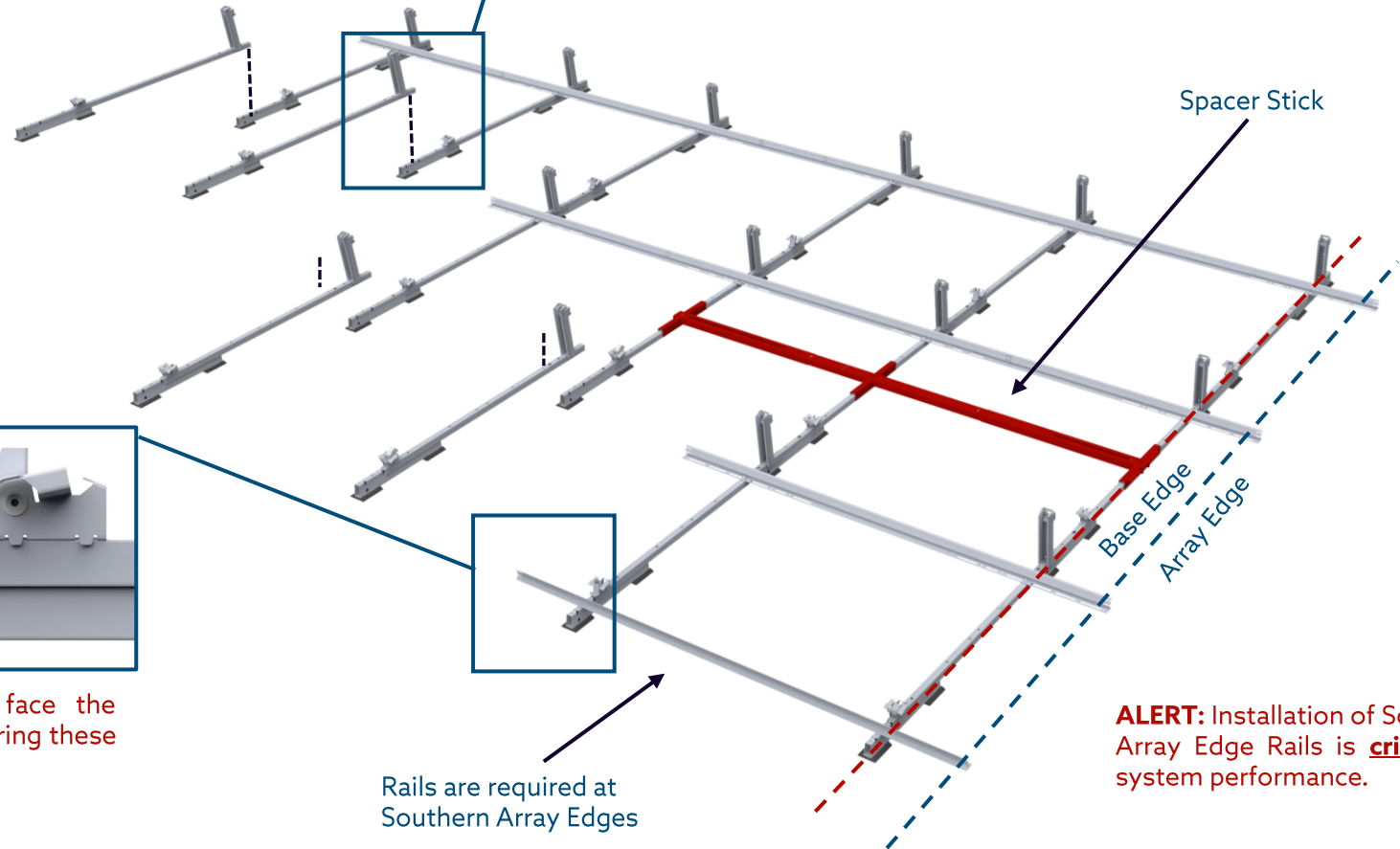

ALERT: Southern Edge Rails face the opposite orientation; bolts securing these Rails are tightened to **6 ft-lb.**

ALERT: Installation of Southern Array Edge Rails is **critical** to system performance.

6. 2000695/2000895 Rail Installation

ALERT: 2000695/2000895 rails are made from steel. If PROJECT PART QUANTITY table in Racking Construction Set includes 2000905 (aluminum rail), skip this step and go to step 7.

6.1 Install a Rail onto array in locations where Ballast is required. Bolt to both Module Connectors and tighten to **6 ft-lb**.

ALERT: Every Rail must be fastened to two Module Connector assemblies.

Tip: Ballast and Rails are only placed on "S" spacings. Center Rails on the "S" spacing.

6.2 Place Ballast onto Rails. If rapid cyclic movement of system is expected e.g., due to seismic activity or building vibration from activities within or nearby the structure, bend the Rail tabs to secure Ballast.

ALERT: Install Mechanical Attachments before going to next step. See Appendix B

Tip: Installing the north row ballast blocks helps keep the racking structure from moving as the rest of the array is built.

6.3 Ballast must be placed as shown. Ballast quantity affects the Ballast placement on the Rails and in some cases additional Rails are required as noted below.

***ALERT:** Modules longer than 2100 mm with 7 or 8 ballast blocks require two (2) Rails. Install Rail 2 on top of Rail 1 and tighten to **6ft-lb**.

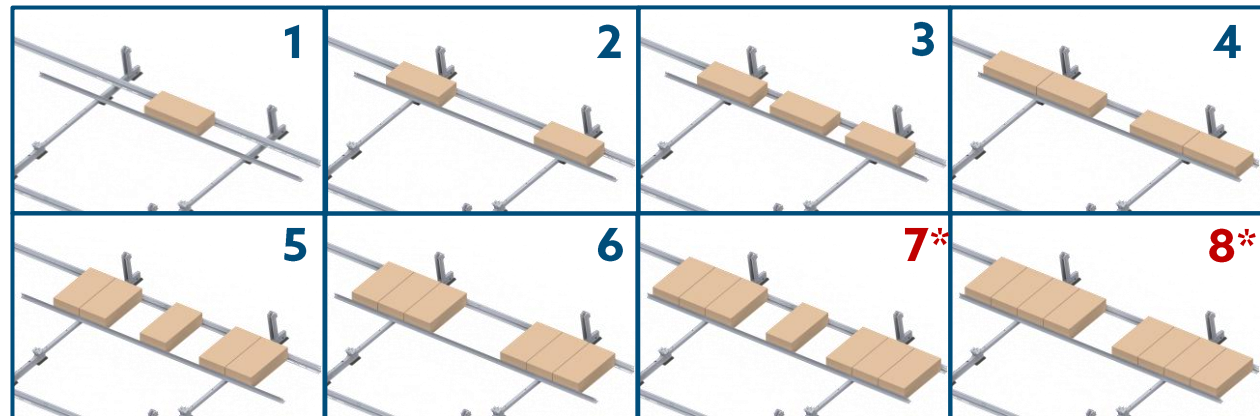
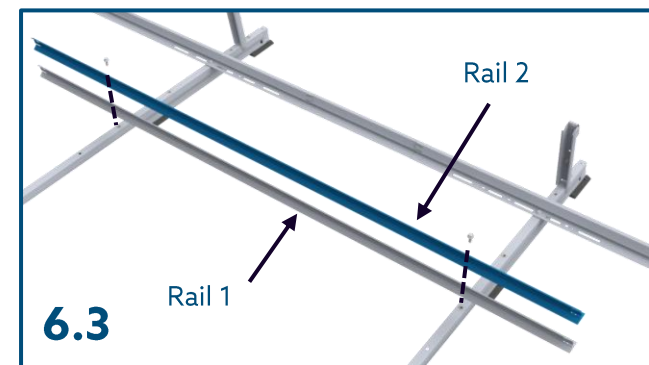
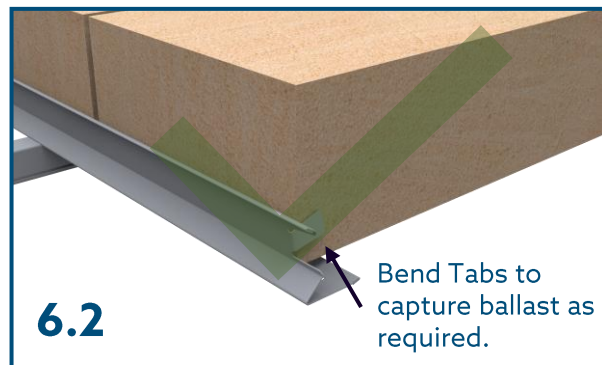
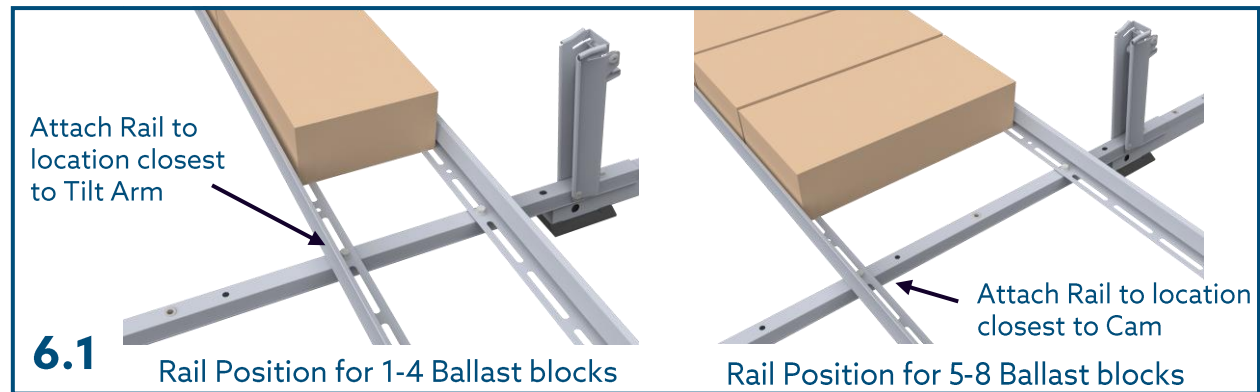

Ballast Positioning for 1-8 Ballast blocks

7. 2000905 Ballast Rail Installation

ALERT: 2000905 rails are made from aluminum. If PROJECT PART QUANTITY table in Racking Construction Set does NOT include 2000905 (aluminum rail), skip this step. Steel rail installation is covered in step 6.

7.1 Install a Ballast Rail onto array in locations where Ballast is required. Bolt to both Module Connectors and tighten to **6 ft-lb.**

ALERT: Every Ballast Rail must be fastened to two Module Connector assemblies.

Tip: Ballast and Ballast Rails are only placed on "S" spacings. Center Rails on the "S" spacing.

7.2 Place Ballast onto Ballast Rails. For proper fitment ensure the long flange of the Ballast Rail is pointed towards the Tilt Arm.

ALERT: Install Mechanical Attachments before going to next step. See Appendix B

Tip: Installing the North row ballast blocks helps keep the racking structure from moving as the rest of the array is built.

7.3 Ballast must be placed as shown. Ballast quantity affects the Ballast placement on the Ballast Rails.

ALERT: When using the 2000905 Ballast Rail, no additional Rails are needed when installing 7 or 8 Ballast Blocks

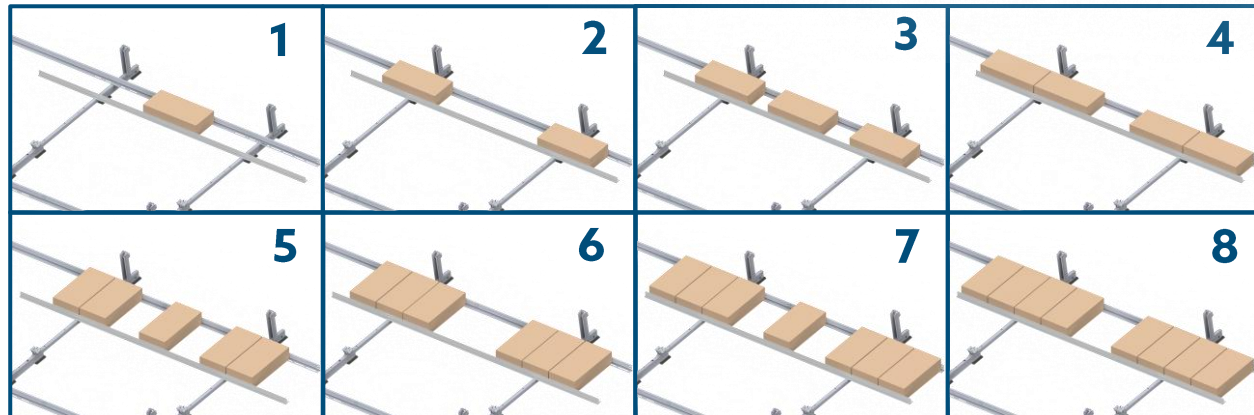
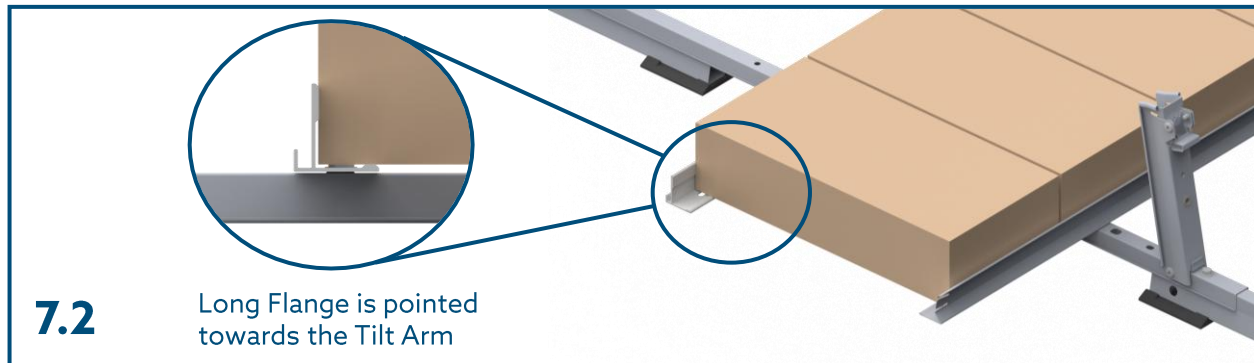
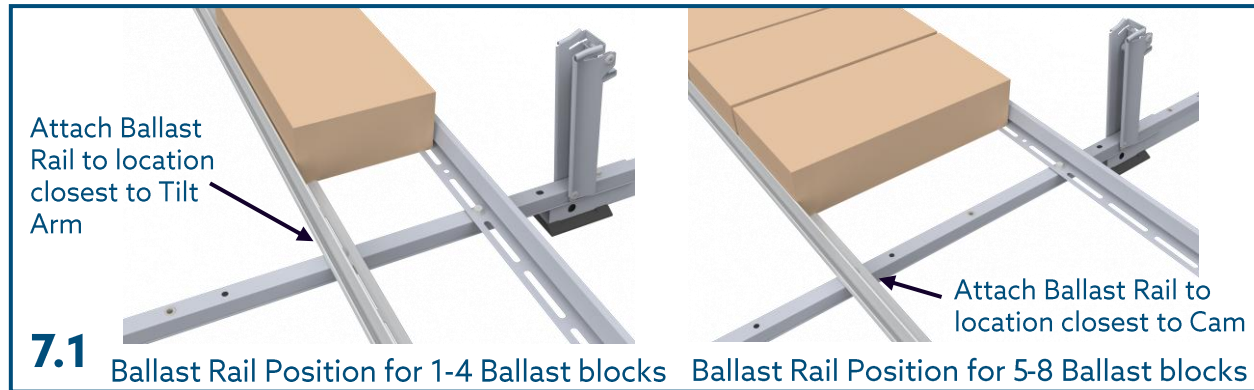

Ballast Positioning for 1-8 Ballast blocks

8. Install Module Low Side

8.1 Starting with the South array edge place module on Cam Seat and align with array edge.

Tip: R dimension is found in the Racking Construction Set. See Sheet Title: **Typical Array Dimensions**

8.2 Ensure the module is vertical and flush against the back of the Cam Seat

8.3 Place Cam Claw over module flange. Apply a small downward force to ensure Cam Claw is fully engaged with the PV Module.

ALERT: After installation, Cam Claw should be in contact with the box section of the module flange.

ALERT: Do not leave modules in vertical position, go immediately to next installation step (high side install).

ALERT: When forecasted wind gusts exceed 25% of the wind speed listed in the site criteria table of the Racking Construction Set, Deflectors must be installed on all mounted modules to avoid possible system damage. This alert is not applicable when the Racking Construction Set does not call for Deflectors.

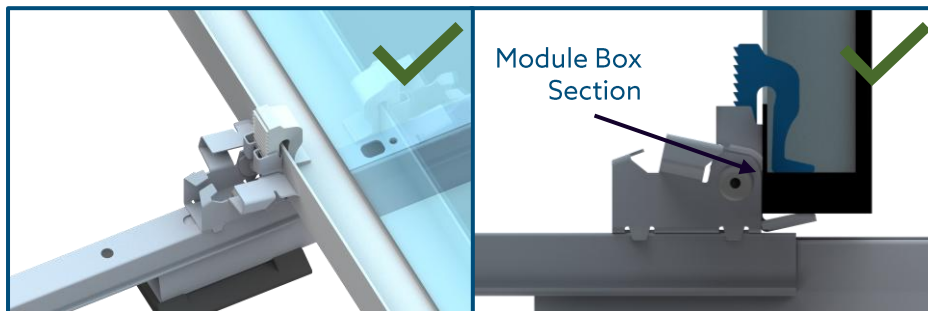
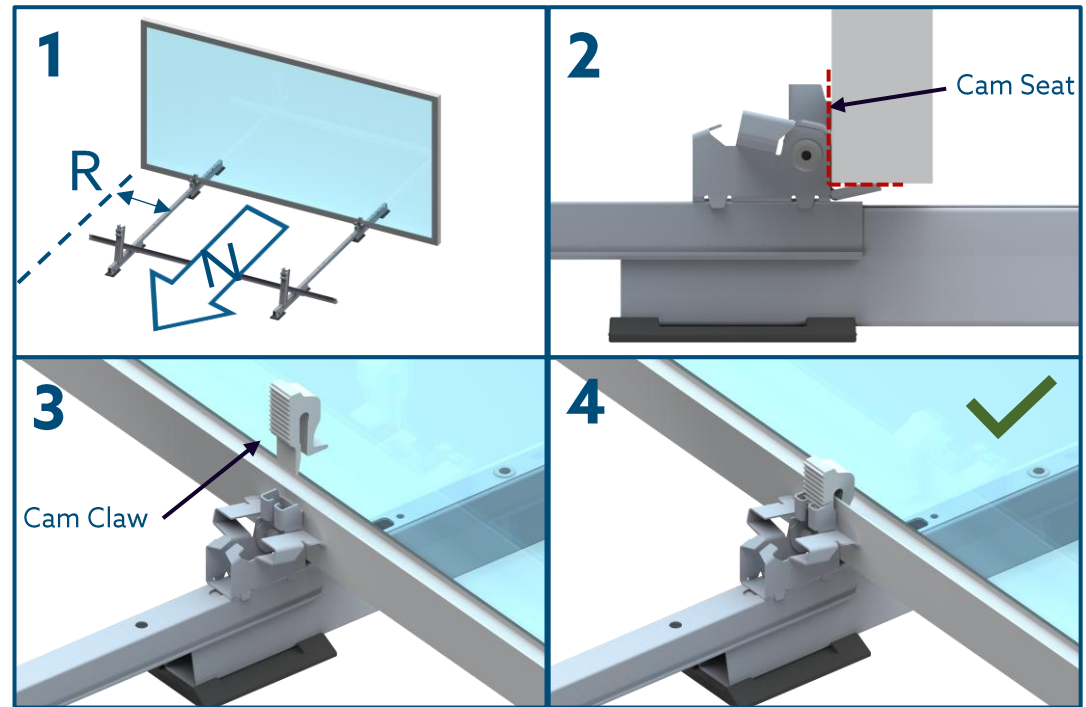

Example of a good installation of the Cam Claw. Cam Claw is straight and is in contact with the inside of the Module frame

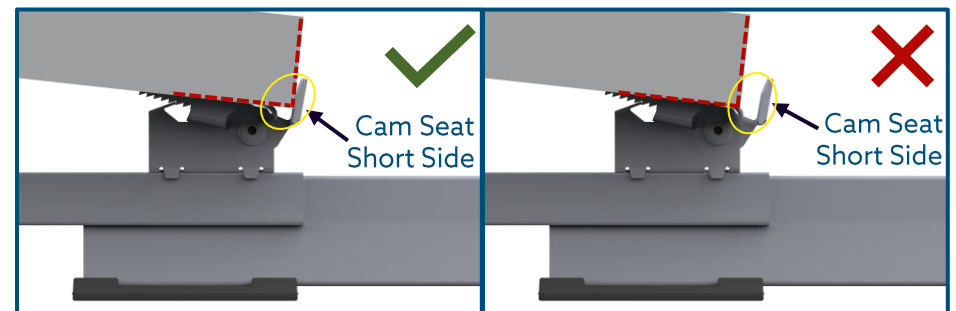

After module installation, the module frame should contact the Cam Seat Short Side as shown.

9. Install Module High Side

Module Installation

- 9.1 Rotate the module down and rest the module frame on top of the Tilt Arms.
- 9.2 Support the module carefully while rotating the Tilt Arm just enough to rest the module frame on the extended portion of the Tilt Arm.
- 9.3 Pull the Tilt Arm forward until the Tilt Arm is firmly in place against the module frame. This ensures the Lock Claw is fully engaged.

Tip: Use two hands when installing the Tilt arm.



Module Removal

- 9.4 To uninstall the module press up on the bottom flange of the Lock Claw and rotate the Lock Claw out.
- 9.5 Rotate the Tilt Arm off the module.

Module Reinstall (Lock Claw Reset)

- 9.6 To reinstall the module, reset the Lock Claw by pressing it back into the Tilt Arm and repeat module installation steps.

ALERT: Failure to reset the Lock Claw will compromise system performance.

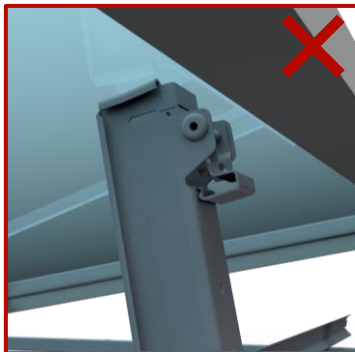
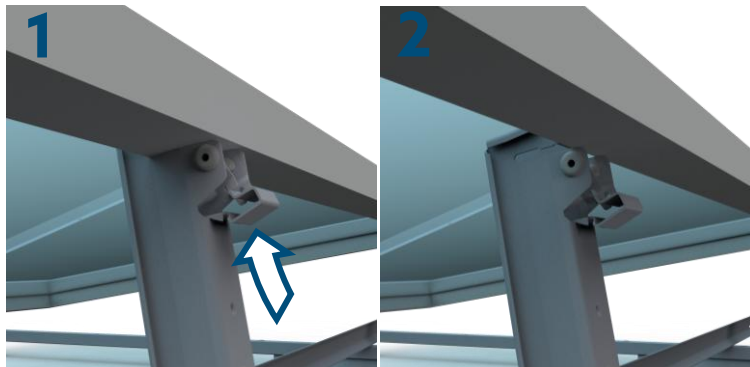

DO NOT REST ON BACKSHEET

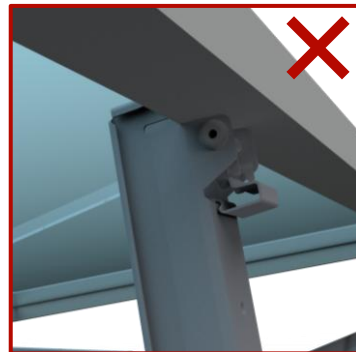

TILT ARM NOT FULLY ENGAGED

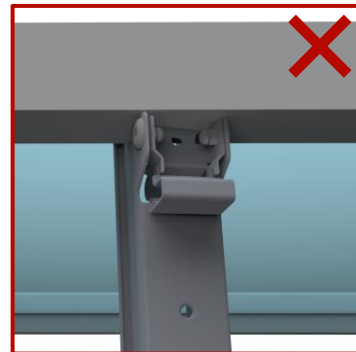

TILT ARM UNEVENLY ENGAGED

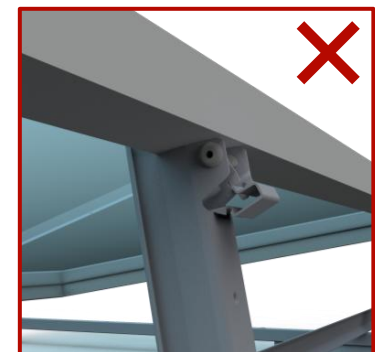

LOCK CLAW NOT INSTALLED

10. Continue Installing Modules

10.1 Starting with the South array edge continue to install modules following Steps 8-9. Use the Cam Claw to set the spacing between modules, approximately 3/4" which corresponds to the width of the Cam Claw.

ALERT: Check the R dimension every 5th module and adjust spacing between modules as needed.

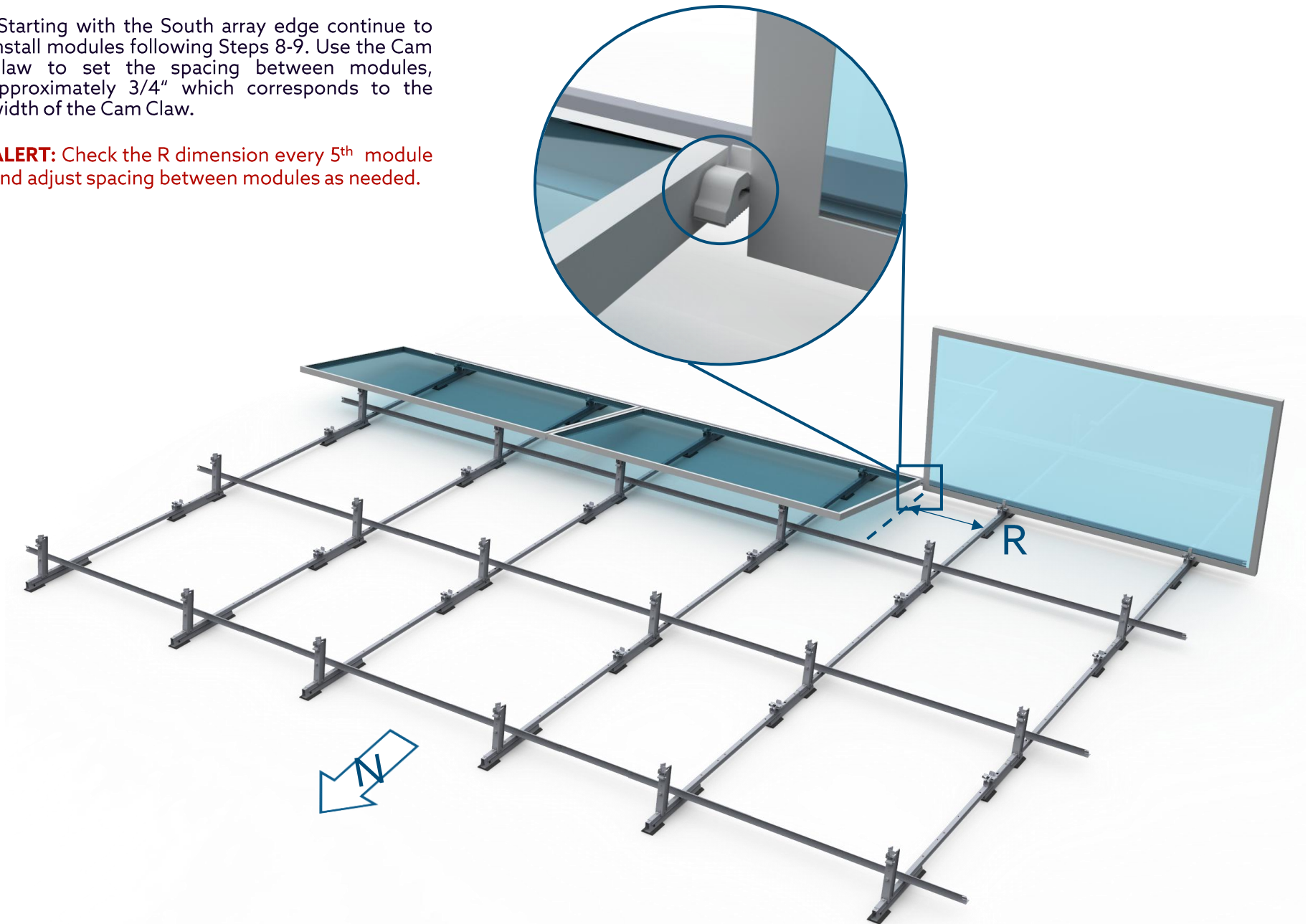

Electrical Grounding

Grounding Overview

The clawFRplus 10 Degree flat roof system can be used to ground and/or mount a PV module complying with ANSI/UL 1703 or ANSI/UL 61730 only when the specific module has been evaluated for grounding and/or mounting in compliance with the included instructions.

PanelClaw components within the array are required to be electrically bonded to the Fault Current Ground Path via the use of appropriately sized Cu wire and a UL 467 listed PV Lug grounding assembly, part number **5000594** or a Tyco Solarlok grounding assembly, part number **2106831-1**. The conductor size should be selected in accordance with NEC 690.45 and NEC 250.122.1.

Please consult with national and local building code(s) for complete grounding requirements for your installation.

A list of approved modules can be found in the PanelClaw "clawFR/clawFRplus UL 2703 List of Ratings and Compatible Modules and MLPEs". The most recent version can be found on the PanelClaw website (www.panelclaw.com/ul-2703).

ALERT: During grounding and bonding ensure there is separation between bare copper and aluminum or coated steel components.

ALERT: Every sub-array must include at least one grounding device/lug.

System Ground Path

The path to ground is established throughout the array by electrically bonding the PV module through the module frame connections on the Module Connector Tilt Arms and Cam Connections. The Module Connectors are bonded to the Rail where the PV Lug or Tyco Grounding lug is installed, as shown below. All other accessible metallic parts are also electrically bonded to the Fault Current Ground Path.

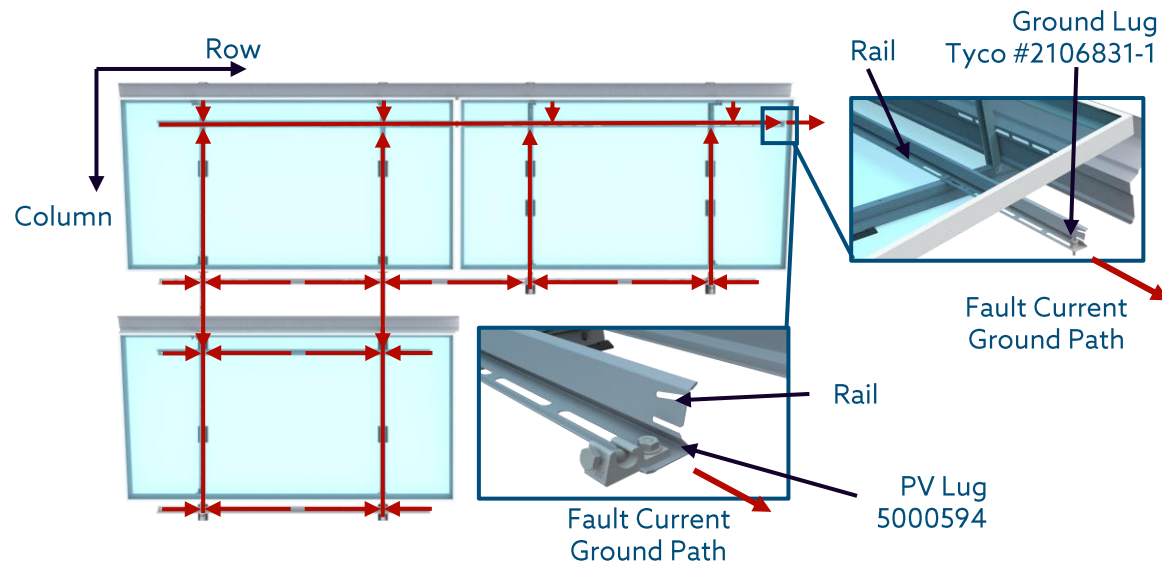

Tyco Grounding lug attachment:

To attach the Tyco grounding device/lug to the Rail, the mounting hex washer and threaded post end should be installed to the specified hole in the Rail and torqued to **2.08 ft-lb (25 in-lb)**. Once the grounding device/lug has been attached to the Rail, a copper grounding wire must be installed to the wire slot end and torqued to **3.75 ft-lb (45 in-lb)**. Refer to the Tyco Electronics instructions sheet (document number 408-10262) via their website www.te.com for additional instructions.

PV Grounding lug attachment:

To attach the PV Lug grounding device/lug to the Rail, the mounting flange nut and bolt should be installed to the specified hole in the Rail and using a 10mm nut driver torqued to **5 ft-lb (60 in-lb)**. Once the grounding device/lug has been attached to the Rail, a copper grounding wire must be installed to the wire slot end and using a 10mm nut driver torqued to **1.67 ft-lb (20 in-lb)**.

Note: During maintenance and servicing where module removal is required, adjacent modules maintain the bond path to the Ground Lug and therefore module jumpers are not required to be installed.

Appendix A: Ballast Blocks

PanelClaw does not provide the ballast blocks required to construct the system in accordance with PanelClaw’s Racking Construction Set drawings.

Ballast blocks for any ballasted rooftop system shall conform to ASTM C1491 or C1884 where applicable. Under these standards, ballast blocks **MUST** be manufactured and tested for freeze-thaw durability. In locations where the quantity of freeze-thaw cycles is less than 25 (see figure below), ASTM C90 standard ballast blocks may be used. Please note the additional block specifications below which may be more stringent than the ASTM specification. It is strongly recommended that installers weigh several blocks on-site to ensure block weights match what is specified on PanelClaw’s Racking Construction drawings.

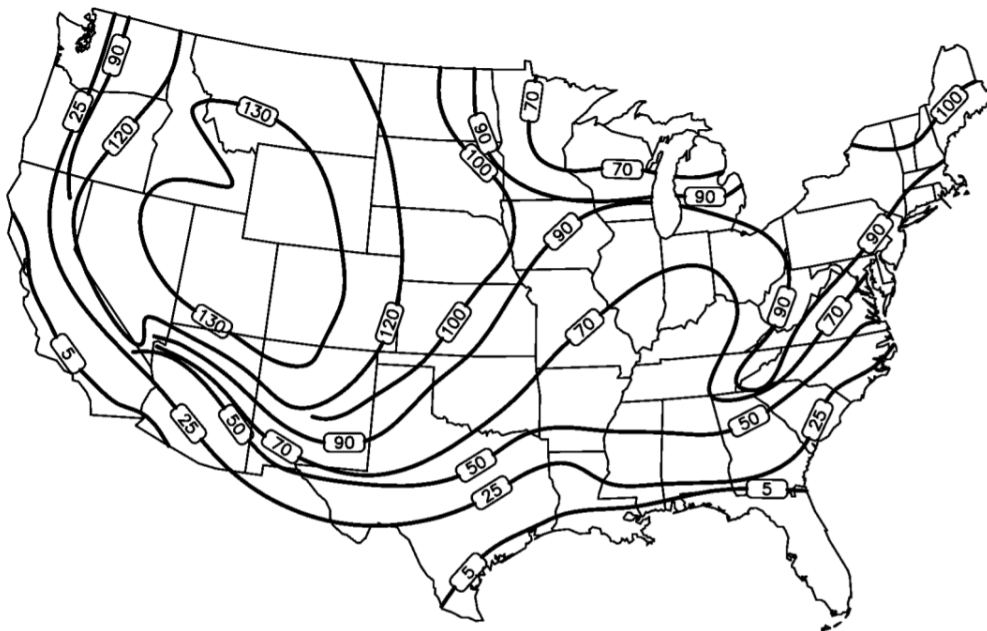

Approximate Number of Freeze-Thaw Cycles Per Year

Minimum Ballast Block Specification		
ASTM Standard	C1491 & C1884	C90
Min. Compressive Strength	2500 psi	2000 psi
Min. Density	125 pcf	125 pcf
Max. Water Absorption	13 psf	13 psf



Ballast Block Description	Nominal Weight* lb [kg]
BLOCK, CONCRETE, 2"X 8"X 16"	14.6 [6.6]
BLOCK, CONCRETE, 3"X 8"X 16"	23.6 [10.7]
BLOCK, CONCRETE, 4"X 8"X 16"	32.6 [14.8]

*Tolerance = ± 5% Nominal Weight

Appendix B: Mechanical Attachment ("MA") Strut

Part Number: 5000423 & 2000930

Tools Required:

Drill with In-Line Torque Limiter or torque wrench

Various sockets (see table)

ALERT: NO IMPACT DRIVERS

Torque Setting*	Fastening Operation
21 ft-lb (29 Nm)	U-bracket EZ connections (3/8" bolts)
6 ft-lb (8.1 Nm)	Mechanical Attachment Strut to Base connection

Socket sizes	Fastening Operation
10 mm Magnetic	Used with 6 mm bolts
9/16"	Used with 3/8" bolts

* +/-4% allowable during installation

ALERT: During installation into the Pilot hole and Torque Clip if applicable. The use of a battery-operated drill (Not impact driver) Should be set to low speed, no clutch (set to drill) and an even amount of force perpendicular to the connection should be applied.

Step 1. Assemble template for components as shown, loosely assemble the U-bracket EZ and MA Strut with the necessary hardware as shown.

Tip: All hardware is included with **5000423** (MA Hardware Kit)

Tip: Install MA's after grid assembly is completed (prior to installing modules).

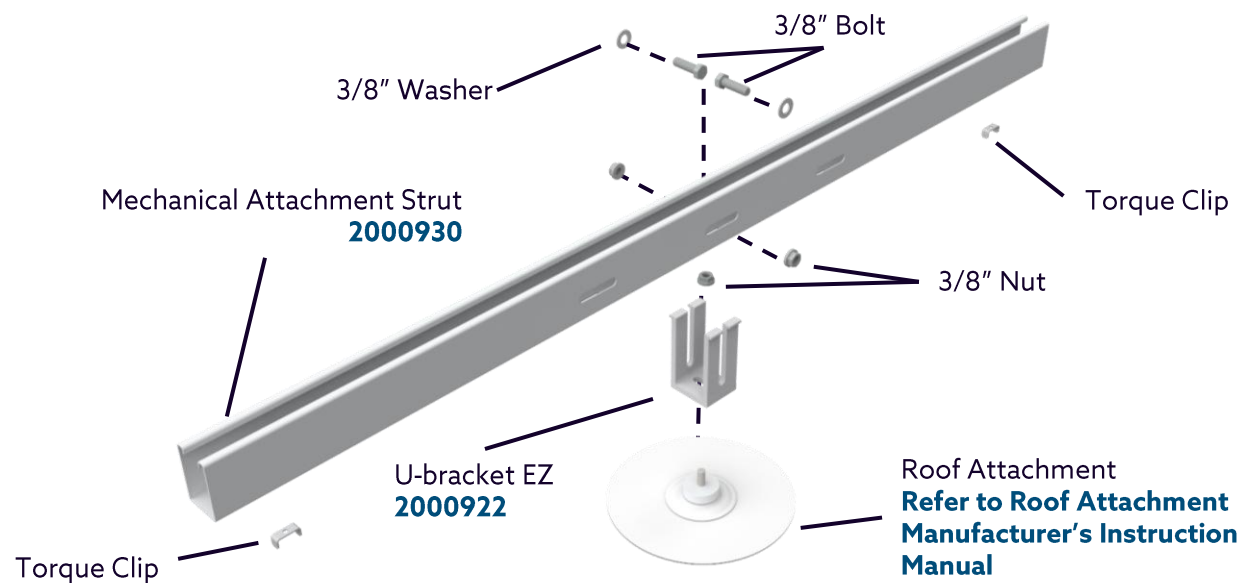

Appendix B (Continued)

Part Number: 5000423 & 2000930

Step 2. Center Strut assembly between Bases at required install location. With a felt marker or other means **Mark** location of Roof Attachment in center slot of U-bracket EZ. **Install** Roof Attachment per manufacturer instructions.

Note: Image shows roof markings at low edge of module, process is the same for all MA installation locations.

ALERT: See Sheet Title: **Ballast Layout -XX** in the Racking Construction Set for installation locations of Mechanical Attachments on each individual project.

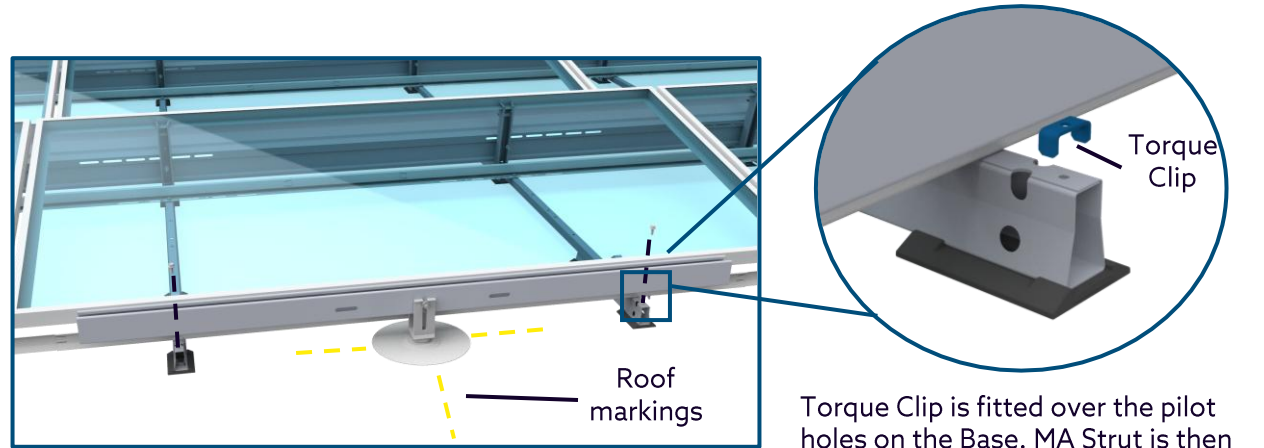

Torque Clip is fitted over the pilot holes on the Base. MA Strut is then aligned with the Torque Clip and Pilot hole before being secured by an M6 Bolt.

Step 3. Install U-bracket EZ to MA Attachment using 3/8" nut provided and tighten. Install torque clips onto the Bases and align with pilot holes. Place MA Strut in center of U-Bracket EZ and align slots with torque clips. Tighten remaining connections as shown.

Tip: Tighten M6 Bolt Connections before tightening 3/8" connections to Roof Attachment.

MA Struts may be installed in several possible array locations.

1. Low Edge Installation
2. High Edge Installation
3. Interior Installation

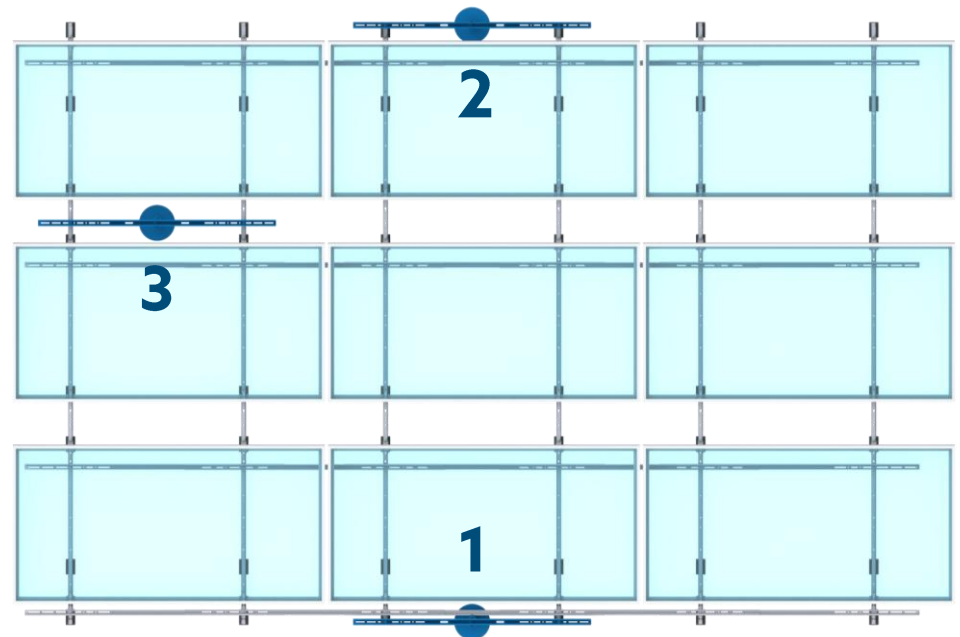

Appendix B (Continued)

Part Number: 5000423 & 2000930

Location 1: Low Edge Location (Typical)

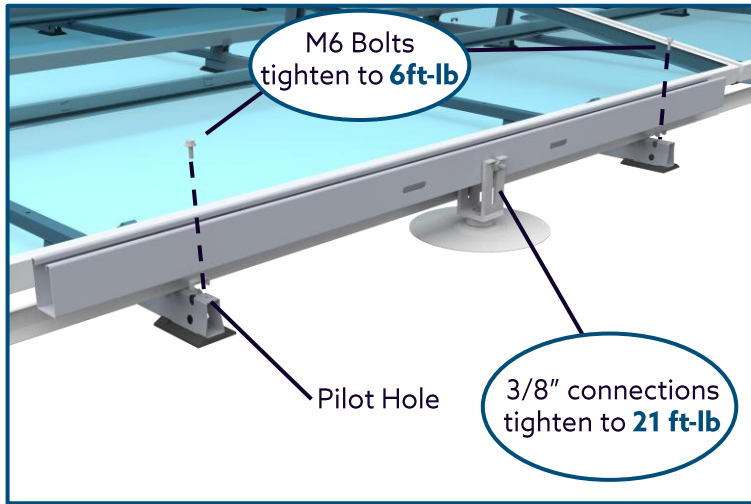

Location 2: High Edge Location (Typical)

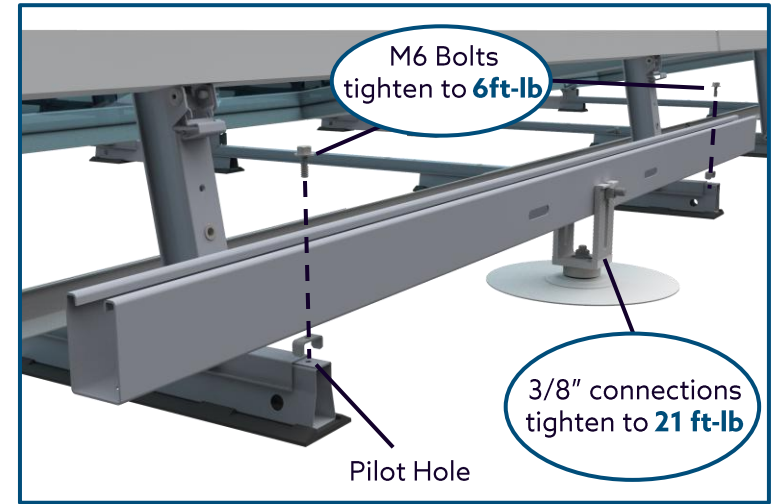

Location 3: Interior Location (Typical)

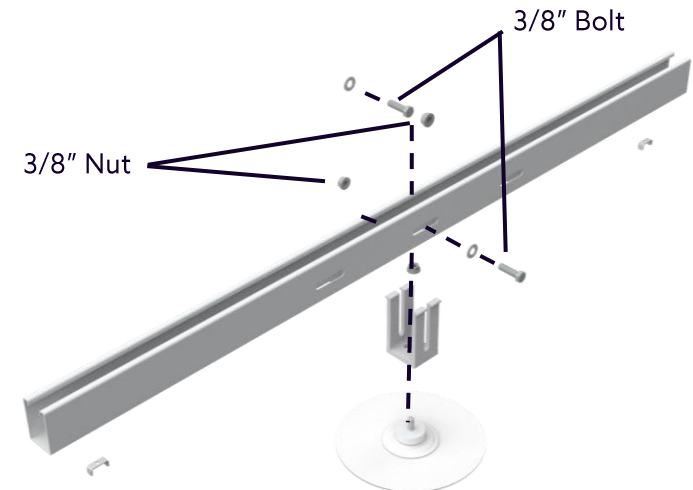
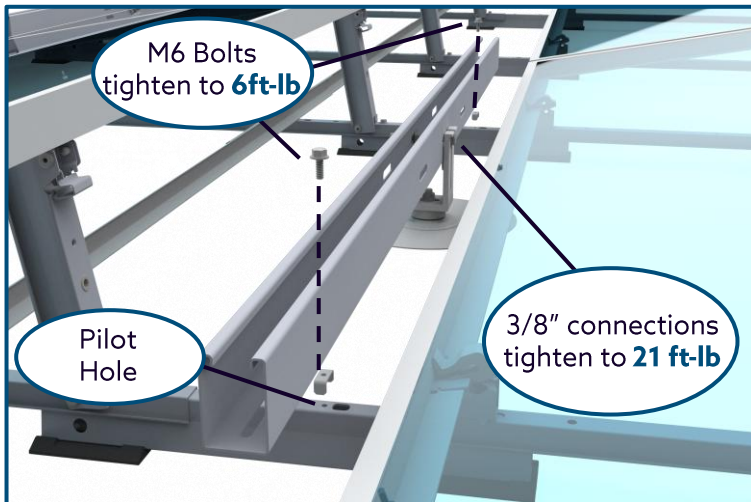

ALERT: When installing the Mechanical Attachment Strut at Location 3, ensure that the bolt closest to the low side of the module is installed with the bolt thread inward to the MA Strut, flipped 180 degrees from the standard orientation. The bolt head should be positioned on the outside of the U Bracket EZ as shown.

Appendix C: Shim Pad

Part Number: 5000228

Some roof systems with slope changes and/or localized undulations may result in cases where the Base Pads are more than 2" off the roof after array grid construction (prior to ballast, module, and deflector installation). If this occurs Shim Pads can be provided and installed on the bottom of the Base Pads to ensure the Base rests on the roof at all contact points.

Each **Shim Pad Pack** includes a total of 50 Shim Pads.

Alert: Shim Pads can not be used to raise an entire array.

Cones nest into holes in Base Pad

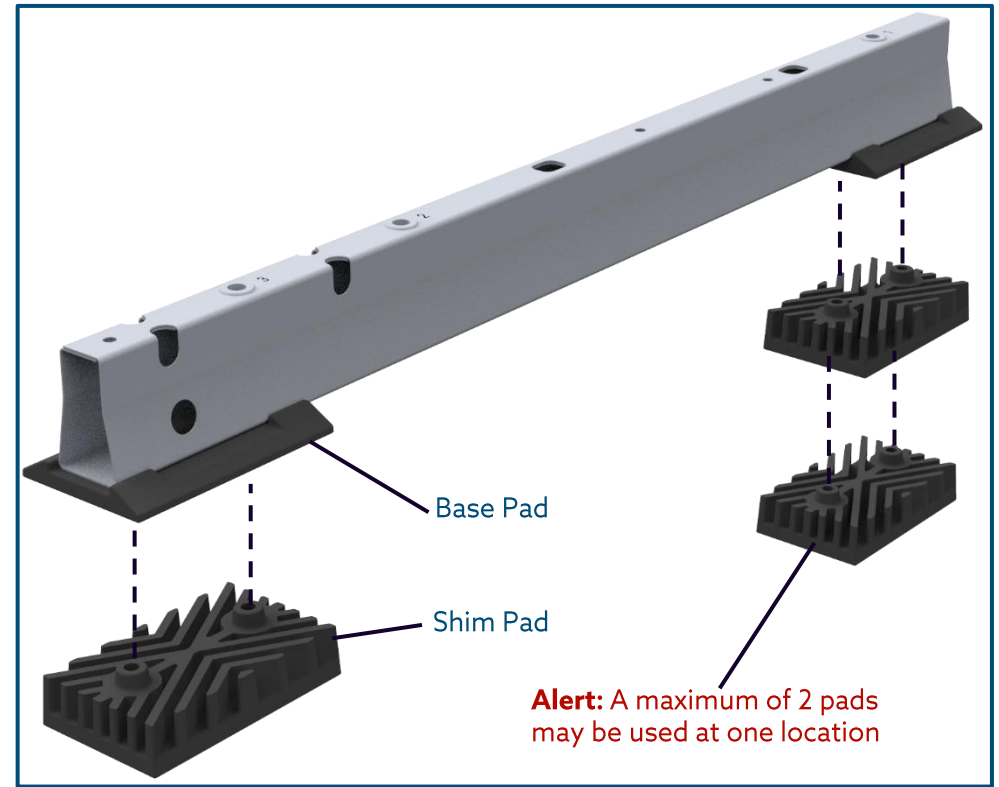
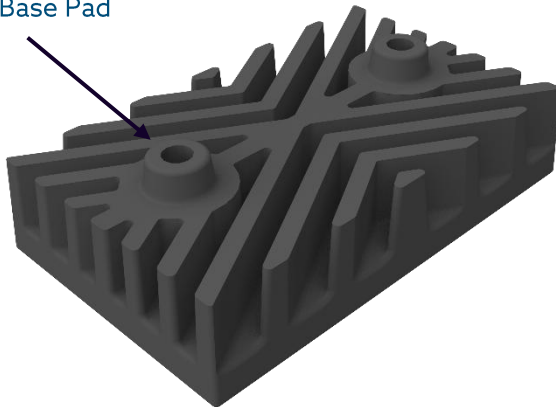

Place the Shim Pads underneath the Base Pads and press firmly.

Tip: Use one or two Shim Pads as shown to ensure each Base rests on the roof at all contact points.

Appendix D: Base Pad

Part Number: 2000678

Some roof systems may need to disperse the concentrated loads of the arrays over more surface area. If this is the case, additional Base Pads can be provided and installed into additional slots on the bottom of the Bases to increase the load distribution to the roof.

Base Pads should be installed during the “Step 2. Build Assemblies” for clawFRplus systems.

Each **Base Pad Pack** includes a total of 350 Base Pads.

ALERT: See Sheet Title Page: **Ballast Layout -XX** in the Racking Construction Set for installation locations of Base Pads on each individual project.

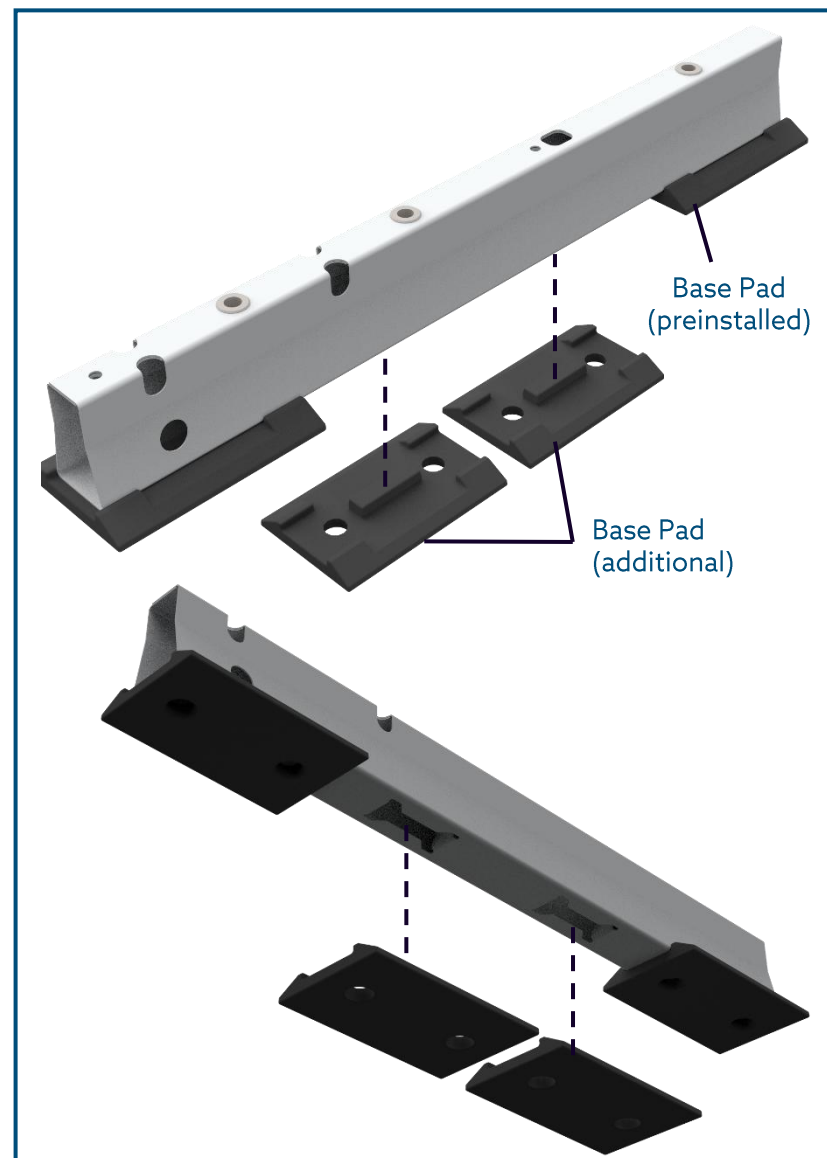
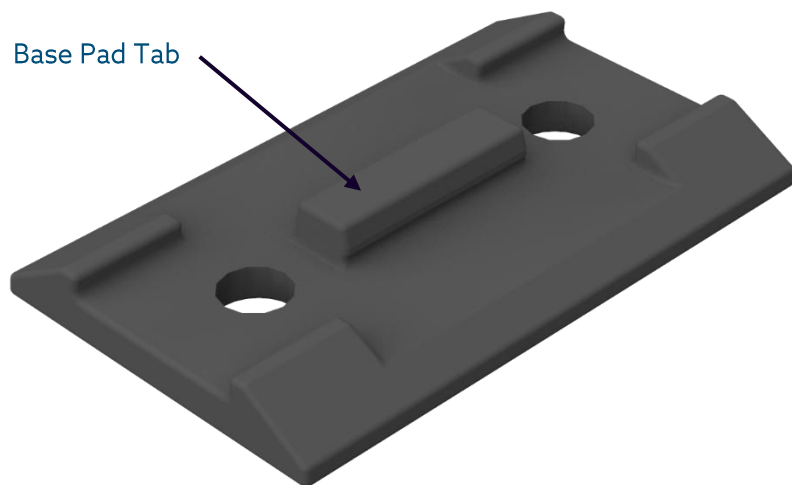

Press Base Pad Tab into slot on Base.

Note: The quantity of slots may vary depending on the Base version.

Appendix E: MLPE Installation

Part Number: 5000619

Tools Required:

Drill with In-Line Torque Limiter or torque wrench

Various sockets (see table)

ALERT: NO IMPACT DRIVERS

Torque Setting*	Fastening Operation
3 ft-lb (4.1 Nm)	MLPE Bracket to clawFRplus system components
6 ft-lb (8.1 Nm)	MLPE to MLPE Bracket and as specified

* +/-4% allowable during installation

Socket sizes	Fastening Operation
10 mm Magnetic	Used with M6 bolts
1/2"	Used with 5/16" bolts

ALERT: 5/16" bolts are used for MLPE installation. Check MLPE installation manual for specific instructions.

The **MLPE Bracket** is UL 2703 approved for bonding. A specific list of compatible MLPEs can be found in the "clawFR/clawFRplus UL 2703 List of Ratings and Compatible Modules and MLPEs" document. The most recent version is available on the PanelClaw website (www.panelclaw.com/ul-2703).

Module Level Power Electronics (MLPE) provide a host of benefits to solar arrays. The MLPE bracket offers a convenient solution for mounting MLPEs to clawFRplus 10 Degree system.

Each **MLPE Bracket Kit** includes the following items (sufficient for mounting 100 MLPEs to clawFRplus)

- 100 - MLPE Bracket
- 100 - 5/16" Flange nut
- 100 - 5/16" Bolt
- 100 - M6 Bolt

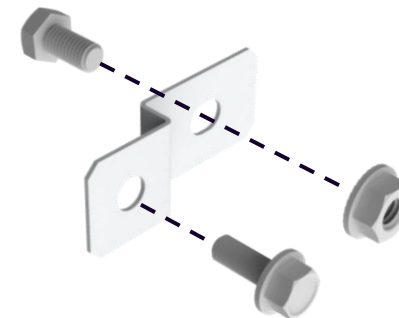

Appendix E (Continued)

Part Number: 5000619

Installation for Location A: Attach MLPE to Tilt Arm using M6 bolts. Torque to **3 ft-lb**.

Tip: Install MLPE to Tilt Arm before installing the module.

Installation for Locations B and C: Attach MLPE Bracket to MLPE Mounting Plate using 5/16" bolt and Torque to **6ft-lb**.

Tip: Preassemble the MLPE Bracket to the MLPE prior to attaching to the system.

Installation for Location D: Attach MLPE to Module Connector using 1/4" Stainless Steel Bolt and Serrated Flange Nut.

ALERT: See next page for acceptable installation locations for each compatible MLPE.

ALERT: During installation into the Pilot hole and Torque Clip if applicable. The use of a battery-operated drill (Not impact driver) Should be set to low speed, no clutch (set to drill) and an even amount of force perpendicular to the connection should be applied.

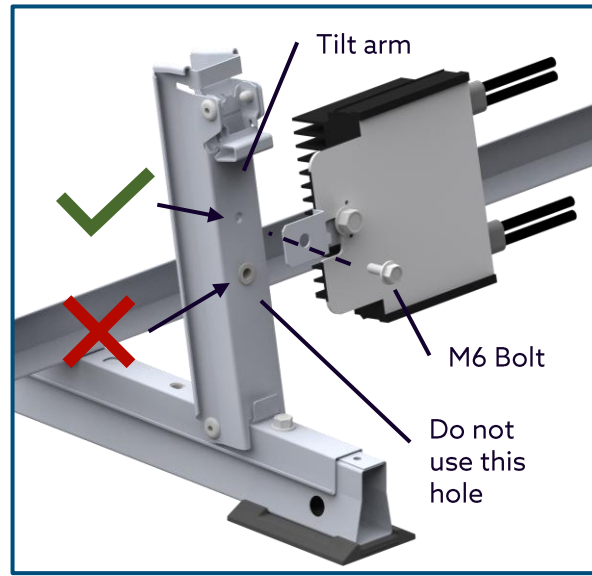

Location A

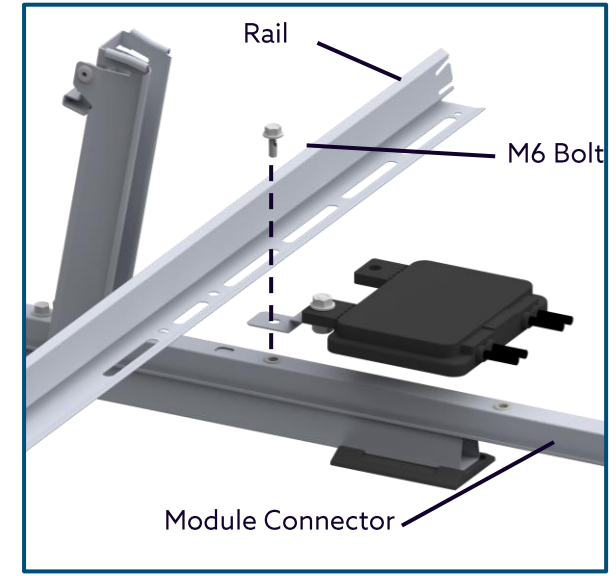

Location B

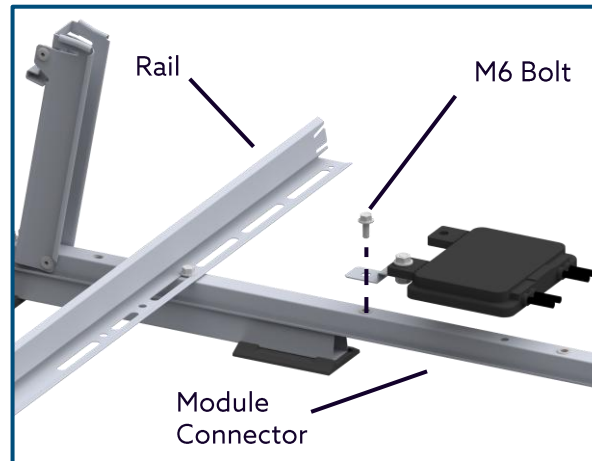

Location C (may or may not have rail)

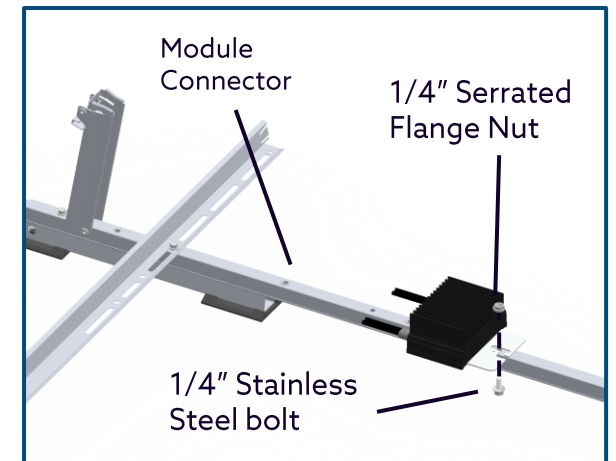

Location D

Appendix E (Continued)

Part Number: 5000619

Solar Edge Installation

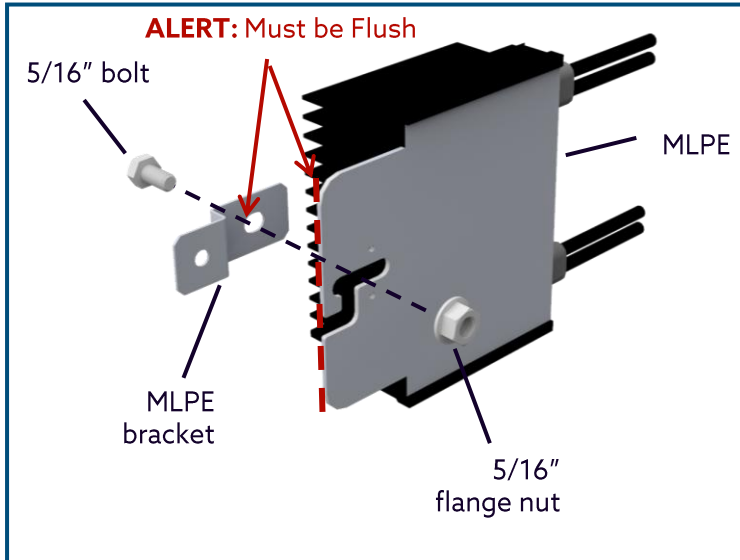

Solar Edge Allowed Installation Locations: A, D*

*Location D uses 1/4" Hardware

Enphase Installation



Enphase Allowed Installation Locations: B, C

Tigo Energy Installation

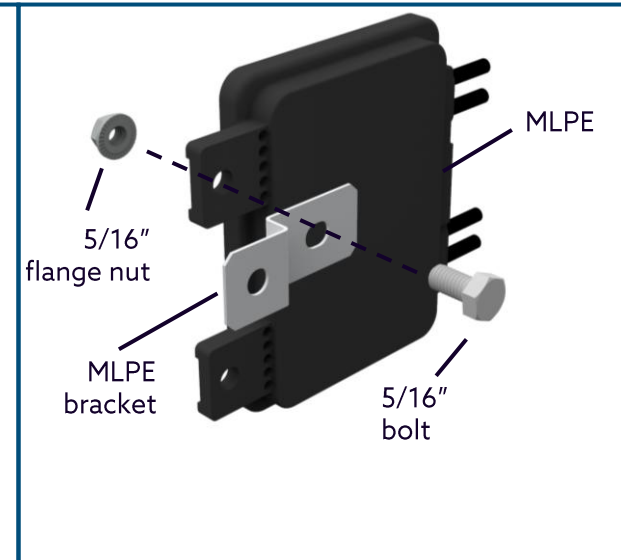

Tigo Allowed Installation Locations: A, B, C

Yotta Energy Installation

Yotta's Dual Power Inverter and SolarLeaf are positioned and installed in the same location as Ballast in the clawFRplus System. The Rails are to be installed at the location closer to the Cam Bracket or the portrait ballast installation position. All fasteners used to install the Dual Power Inverter or SolarLeaf, including any fasteners removed for installation should be torqued to 6ft-lb.

Alert: When SolarLeaves are installed, they become a critical component of the Main Wind Force Resisting System. If SolarLeaves are removed, quantity 2 4"x8"x16" Nominal 32.6 lbs Ballast Blocks must be placed in these locations.

Alert: See Yotta's Installation manuals for full installation instructions on both the Dual Power inverter and SolarLeaf

Alert: SolarLeaf is to be positioned so it is outside of the 3" module centerline keep out zone.

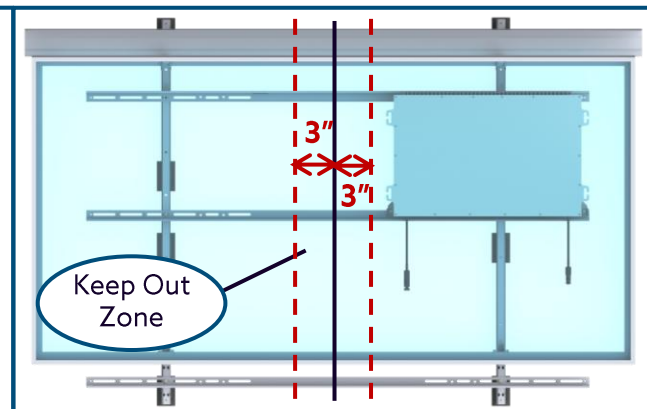
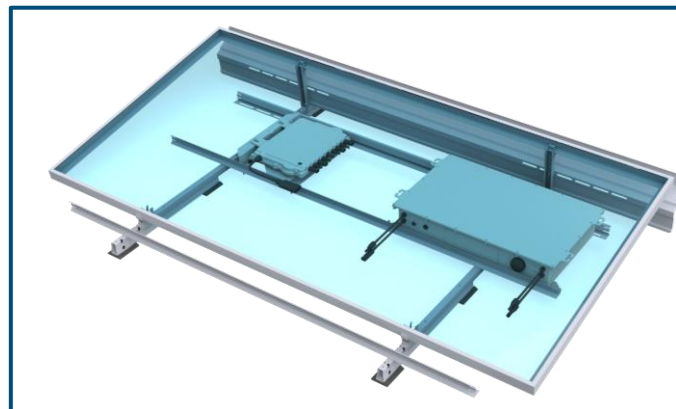

Appendix F: Safety

The subsections below outline some of the obvious / major hazards that could exist during the installation or O&M of PanelClaw products and are divided to bring a level of clarity to such hazards. Some sections do not apply to all PanelClaw product lines and such exclusions are noted within each section.

Electrical Hazards: PanelClaw products are purely mechanical and do not contain any electrically live parts. When a photovoltaic module is exposed to sunlight it is electrically live and cannot be turned off. As soon as modules are installed using a PanelClaw system, an electrical shock hazard is present. All personnel on site should coordinate to ensure that such electrical hazards are clearly communicated. It is advised, at a minimum, that all personnel utilize caution and proper Personal Protective Equipment as outlined in that section. Only electrically qualified personnel should perform PV module installation. Refer to OSHA Part 1926 Subpart K – Electrical and NFPA 70E for additional information.

Environmental Hazards: Look for hazards associated with water and snow loading if observed upon entry into the array area. Standing water increases the likelihood of electrical shock if the PV electrical system is compromised in any way. Severe snow loads can result in module and/or racking damage and, in extreme cases, electrical hazards.

Fall Hazards: This section only applies to clawFRplus products installed on locations six feet or higher above grade. Proper fall protection should be in place at all work sites. There are many fall protection solutions readily available to help reduce exposure to fall hazards. These may include personal fall arrest systems, safety nets, guardrails, and flagged setbacks from all roof edges as outlined in OSHA Part 1926 Subpart M – Fall Protection.

Trip Hazards: All PanelClaw arrays have elevated components that are installed above grade or above a roof surface. Such hazards should be identified and caution should be taken to avoid tripping over such components. Refer to the Fall Hazards section specifically if working with the clawFRplus product line. Make sure to pick up and not drag your feet when working on site, and always pay attention to your path of movement to note any obstructions that could create a trip hazard.

Lifting Hazards: The PanelClaw installation process involves lifting of heavy items that could lead to personal injury and damage to property. All personnel should be trained in the proper procedures for manually lifting. Evaluate an object's size and weight prior to lifting, and follow these general guidelines for lifting:

1. Assess the lift and know the object weight.
2. Bend at the knees and get a good grip.

3. Keep back straight and lift straight up with legs without twisting. It is important to lift with the legs and not the back.
4. If an object is too large or heavy, ask for help and do not attempt to lift by yourself. In the case that mechanical assistance (e.g., crane, forklift, etc.) is required to complete the lifting operations, all machine operators of such devices should be licensed and trained.

Material Handling: All PanelClaw parts and components are made of aluminum and steel alloys and utilize stainless steel assembly hardware. These materials are considered non-toxic and require no special handling procedures. Metal components may have sharp edges, so be sure to handle with care and utilize proper personal protection equipment, especially gloves, during handling. Refer to OSHA Part 1926 Subpart H – Materials Handling, Storage, Use, and Disposal for additional information.

Personal Protective Equipment (PPE): All personnel should utilize and implement proper PPE per OSHA requirements. Refer to OSHA requirements for proper use and implementation of PPE. The following items are suggested as a minimum to avoid injury based on the installation procedure outlined in this manual:

1. Appropriate work clothing
2. Electrically insulated hard hat
3. Protective eyewear
4. EH rated safety boots
5. Gloves
6. High-visibility safety vest
7. Hearing protection

1. If any PPE appears to be defective, stop the use of such equipment immediately, and ensure it is replaced before work continues. Refer to OSHA Part 1926 Subpart E – Personal Protective and Life Saving Equipment for additional information.

Hand and Power Tools: Access to all hand and power tools should be regulated and controlled at all times on site to prevent improper use and related injuries. When not in use, all equipment should be stored in a secured location. Only personnel who have been properly trained in the safe operation of any potentially dangerous tool should be allowed access. All required tools to perform the installation of PanelClaw racking are outlined in the installation procedure. All tools should be inspected daily and before use by the operator. If any tool appears to be defective, stop the use of such equipment immediately, and ensure it is replaced before work continues. Electrical power tools should follow proper lock-out tag-out procedures per OSHA requirements. Refer to OSHA Part 1926 Subpart I – Tools – Hand and Power for additional information.